



INSTRUCTION MANUAL

MVX

Millivolt Transmitter

Form 108-701-00B

April 2016

ADDENDUM

If You Have Ordered A 2-Wire Transmitter in the DIN HOUSING,

Please Note The Following Information:

1. This manual is written for the HOCKEY PUCK (HP) configuration, and is currently undergoing revision to incorporate the DIN housing. However, the information provided here *does apply* to the DIN configuration since both units use the same basic schematic diagram and parts layout profile.
2. If the built-in test points are used to measure the output of a DIN unit, the milliammeter used must have an internal impedance of 10 ohms or less to avoid compromising the measurements. In this case no external resistance is required.
3. For thermocouple input units, the temperature compensating resistor is embedded in the terminal block.
4. Please refer to the following outline and installation drawing (#700-710-54) for information needed to install and hookup the DIN configuration transmitter.

1.1 SCOPE OF MANUAL

This manual contains operating and maintenance information for the Moore Industries Model MVX 2-Wire Millivolt Transmitter.

The manual is divided into six sections.

Section 1, General Information, introduces the function of the unit and describes its physical appearance. Specifications and available options for the unit are listed. This section also explains how to use the Moore Industries model numbering system.

Section 2, Calibration Procedures, provides information to check out the unit before installation. Tools required for calibration are listed and test setups are illustrated. This section also offers all the information and procedures required to calibrate the unit in any configuration.

Section 3, Installation & Operation, offers all the information needed to install and operate the unit. This section contains dimensioned outline drawings that specify installation requirements. The text outlines recommended wiring practices and identifies the electrical connections for each unit. This section also suggests a brief, periodic visual check of the unit during operation.

Section 4, Theory of Operation, gives maintenance personnel a detailed explanation of the internal operation of the unit. Theory is based on a block diagram that shows the functional elements of the unit. The operation of each functional element is described, first in relation to other elements, then independently with a detailed explanation of each major component.

Section 5, Maintenance, offers complete disassembly procedures for each configuration of the unit. This section covers troubleshooting and offers tips and component replacement techniques to aid the technician who must make repairs.

Section 6, Unit Documentation, acquaints the user with Moore Industries computerized parts listing and identification system. This section also provides a recommended spare parts list. The schematic(s) and parts assembly drawing(s) referred to in the text are located at the end of Section 6.



FIGURE 1-1
"HOCKEY PUCK"

The terms *NOTE*, *CAUTION*, and *WARNING* are each used with a specific meaning throughout this manual. A *NOTE* provides additional information that makes it easier to perform a particular task, a step in wiring or disassembly, for example. Failure to follow a *NOTE* may result in some inconvenience or needless expense, but the unit will not be damaged, nor is the instrument technician likely to be injured. A *CAUTION* stresses important details to follow, when making electrical connections or cleaning PC board contacts, for example. Failure to heed a *CAUTION* may damage the unit, void the Moore Industries warranty, or even result in minor physical injury to the instrument engineer. A *WARNING* provides vital safety information which must not be ignored on any account. *WARNINGS* deal with proper grounding of equipment, use of solvents, etc.

1.2 UNIT FUNCTION

The MVX is a 2-wire millivolt transmitter. Connected in series with a 12-42 Vdc power source and a resistive load, the MVX converts millivolt input to proportional current output. The MVX accepts input from any standard millivolt source. Output is a standard 4-20 mA analog process signal. Optional 10-50 mA output is also available.

1.3 STANDARD UNIT PHYSICAL DESCRIPTION

The MVX consists of two printed circuit boards that hold all the electronic components. A small additional board is mounted vertically across the center of the main board. This small board provides the circuit strip connections for the plug-in connector and the potentiometers required for calibration.

The boards are enclosed in an oval protective housing of extruded aluminum. Electrical connections information is given in Section 3, Installation and Operation.

1.3.1 "Hockey Puck" (MVX/HP)

In its HP configuration, the MVX printed circuit boards assembly is mounted inside an oval protective housing of extruded aluminum that resembles a "hockey puck." With FL option flanges supplied as standard, the unit can be surface mounted, or it will snap into a relay track. Remove the flanges and place the unit inside a standard conduit® for explosion proof field mounting. (See Figure 1-1).

1.4 EXPLOSION-PROOF UNIT, PHYSICAL DESCRIPTION

The explosion-proof enclosure option consists of the standard enclosure described in paragraph 1.3, inserted into a two-piece cast faraloy GUA conduit®. The two pieces consist of a screw-type cover and a housing with hubs. The standard enclosure is modified mechanically to allow mounting into the explosion-proof housing. The modification consists of an additional spring assembly that wedges the standard unit into place. (See figure 1-2).

© Reg. Tradename of Crouse-Hinds

1.5 RF UNIT PHYSICAL DESCRIPTION

The RF unit option consists of standard MVX electronics with the addition of an RF filter input. An RF filter replaces the standard input connector with input and output connections being effected through a flex cable wired between the PC board and the filter. This configuration mechanically fastens the housing cover to the PC board; thus both assemblies must be removed together for maintenance.

1.6 SPECIFICATIONS

The specifications for the unit are listed in Table 1-1.

1.7 MODEL NUMBERS

The Moore Industries model number identifies the type, functional characteristics, operating parameters, and any options that may have been included on a unit. If all documentation for a particular MVX is missing, the model number on the unit can be used to obtain technical information by following the example of Table 1-2.

The "hockey puck" (HP) and explosion proof (EX) units have the model number stamped on the stainless steel identification label on the enclosure cover.

1.8 SERIAL NUMBER

A complete history is kept on every Moore Industries MVX. This information is keyed to the serial number of the unit. When service data is required, please provide the factory with this serial number as well as the model number.

For the "hockey puck" (HP) and explosion proof (EX) units, the serial number is engraved into the printed circuit board.



FIGURE 1-2
EXPLOSION PROOF (EXH2) OPTION

TABLE 1-1
UNIT SPECIFICATIONS

INPUT: D.C. millivolts

- Range:** 5-10 mV
10-20 mV
20-40 mV
40-80 mV
80-160 mV
160-320 mV

Bias Current: Limited to 20 nanoamperes

ADJUSTMENTS: Twenty-two turn potentiometers

Span: Adjusts output to full scale over entire input range

Zero: Adjusts output to 0% for offsets of up to $\pm 10\%$ of full scale input

OUTPUT:

Operational feedback amplifier current source

4-20 mA (limited to 30 mA maximum)

10-50 mA (limited to 65 mA maximum)

Ripple: Less than 20 mV p/p @ maximum load and maximum span

Load Capability:

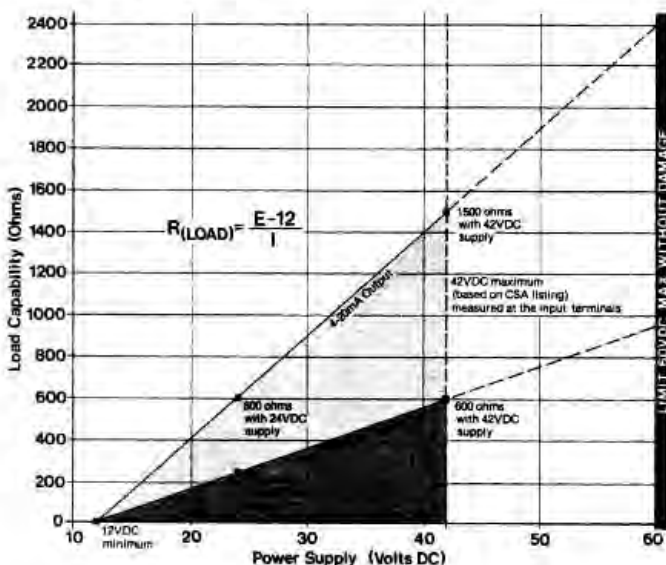

PERFORMANCE

Calibration Capability: $\pm 0.1\%$ of span (Linearity & Repeatability)

Ambient Temperature:

Range: -29°C to $+82^{\circ}\text{C}$ (-20°F to $+180^{\circ}\text{F}$)

Effect on Amplifier: $\pm 0.01\%$ of span/ $^{\circ}\text{F}$

($\pm 0.02\%$ of span/ $^{\circ}\text{F}$ for LSA option)

Frequency Response: 10 Hz (-3 dB point)

Isolation: Input and output are transformer isolated with no galvanic path (dc connection) between them; common mode rejection exceeds 100 dB @60 Hz (500 V RMS limit)

POWER: 12 Vdc (min) to 42 Vdc (max) measured at input terminals. (Limit imposed by CSA)

Overvoltage 60 Vdc (max) without damage

Supply Voltage Effect $\pm 0.01\%$ of span/Vdc change

OPTIONS:

EZX Elevated Zero, "X" = mV offset, required on all units exceeding zero adjustment capability

LSA Low Input Span, 5-10 mV full scale (Calibration Capability $\pm 0.25\%$ of span)

RF Patented terminal strip with filters and ground plane for RFI/EMI protection, exceeds SAMA standard

HOUSINGS:

HP Aluminum case, illustrated

FL Aluminum case (HP) with mounting flanges

EXH2 Explosion proof enclosure for Class I, Groups C & D; Class II, Groups E, F, & G; and Class III environments

Crouse-Hinds GUJ series condulets®

CERTIFICATION:

Canadian Standards Association applied for

WEIGHT: 141.5 grams (5 oz), without EX enclosure

1.36 kilograms (3 lb), approximate, with EX enclosure

ORDERING INFORMATION: Specify the following:

- 1 Input range
- 2 Output span
- 3 Power
- 4 Option(s)
- 5 Housing

SAMPLE MODEL NUMBER:

MVX/10-20mVFS/4-20mA/12-42Vdc/-EZ15-RF[EX]

**TABLE 1-2
MODEL NUMBER EXAMPLE**

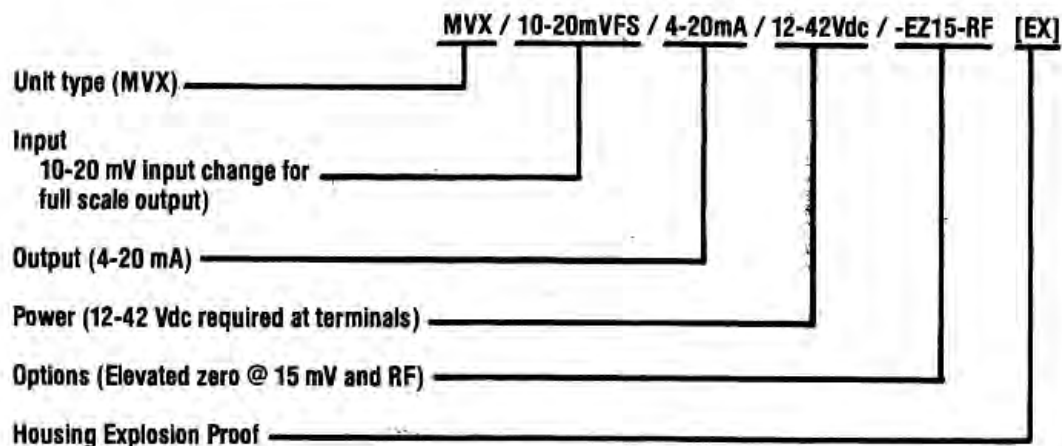

**TABLE 1-3
MVX ELECTRICAL OPTIONS**

OPTION DESCRIPTION	CODE
Elevated Zero, "X" = mV offset, required on all units exceeding zero adjustment capability	EZ(X)
Factory Calibration	FC
Patented terminal strip with filters and ground plane for RFI/EMI protection	RF
Low Input Span, 5-10 mV full scale (Calibration Capability $\pm 0.25\%$ of span)	LSA

2.1 GENERAL INFORMATION

This section provides information about unit calibration. Units with standard input and output levels are normally calibrated at the factory. After the unit is unpacked, general operating level checks of units are recommended. Usually these checks, specified in this section under calibration procedures, require little or no adjustments. If units are ordered with factory calibration, an exact calibration is performed at the factory. Adjustments should not be made in the field on these units unless a new range of input or output signal level is desired.

2.2 CONTROLS

The external controls consist of ZERO and SPAN adjustments located on the front panel of the unit. Each control is a multiturn potentiometer that is adjusted with a blade screwdriver.

CAUTION

USE A BLADE SCREWDRIVER NOT MORE THAN 2.54mm (0.1 INCH) WIDE. A WIDER BLADE MAY PERMANENTLY DAMAGE THE POTENTIOMETER MOUNTING.

The ZERO and SPAN pots usually require 20 turns of the shaft to move the wiper from one end of its range to the other. The pot is equipped with a slip clutch at either end of its travel to prevent damage if it is turned beyond the wiper stop. Slightly more torque is required to turn the shaft when the clutch is slipping. If this change cannot be observed, however, either end of the pot can be reached by 20 turns of the shaft in the desired direction.

Clockwise on the control increases the quantity or makes it more positive. Counterclockwise decreases the quantity or makes it more negative.

2.3 EQUIPMENT AND TOOLS

The necessary test equipment and the tools required to calibrate the MVX are listed in Table 2-1. This equipment and these tools are not supplied and must be provided by the user at the installation or test site.

NOTE

WHEN CALIBRATING AN RF OPTION UNIT, A PLASTIC SCREWDRIVER ALIGNMENT TOOL MUST BE USED. OTHERWISE, RFI IMMUNITY IS LOST AND ADJUSTMENTS MAY BE MEANINGLESS.

2.4 TEST EQUIPMENT SETUPS

Off-line calibration for all units require the same test equipment setups regardless of option or physical configuration; however, the hookup requirements and physical preparations may vary on some units. The following paragraphs define the general test and setup and identify the units that require special attention for test preparation and connections.

2.4.1 General Equipment Setups

The test equipment setup required for calibration of all units is identical except for connection identification. Figure 2-1 shows the general test setup configuration.

TABLE 2-1
TEST EQUIPMENT AND TOOLS REQUIRED

EQUIPMENT OR TOOL	CHARACTERISTIC	PURPOSE
Screwdriver (Blade)	Blade not wider than 2.54 mm (0.1 inch)	To adjust ZERO and SPAN
Calibrated Adjustable Millivolt Source	Leeds and Northrup Millivolt Potentiometer, Catalog No. 8690, or equivalent, accurate to $\pm 0.05\%$ or better	To simulate input
Digital Multimeter	Keithley 171, or equivalent, accurate to $\pm 0.05\%$ or better	To monitor the output signal
Power Supply	12-42 Vdc	To power the unit

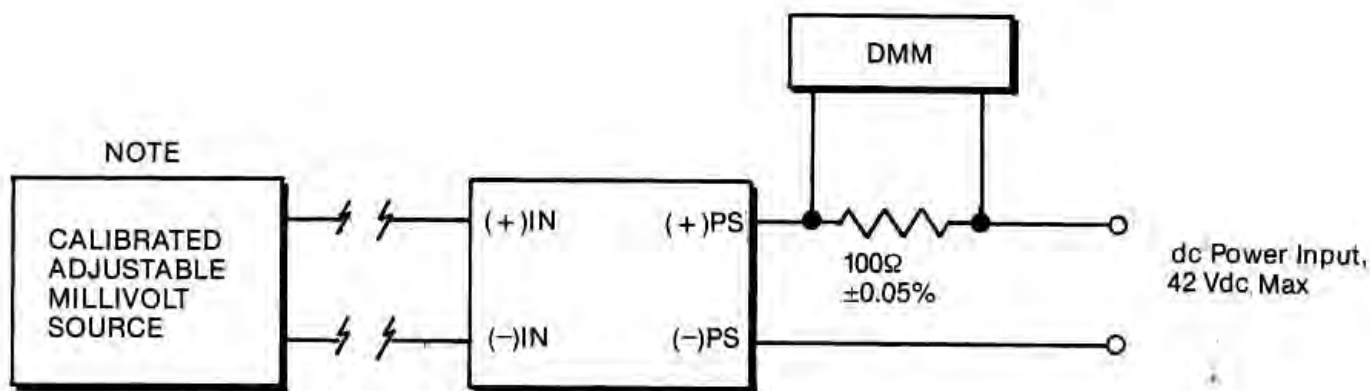

Note Millivolt source accurate to $\pm 0.05\%$, or better

FIGURE 2-1
CHECKOUT/CALIBRATION TEST SETUP

2.4.2 Explosion-Proof (EX) Test Setup

Figure 2-1 also shows the general test setup configuration for a unit installed in an explosion-proof enclosure. Note that in the explosion-proof configuration the protective housing must be opened to expose the connection block.

2.5 CALIBRATION OF UNITS

Units are calibrated and checked for proper performance at the factory before they are shipped. However, unless calibration was requested to a specific set of input-output values, the unit performance should be checked by the user before the unit is placed in service. Calibration consists of simulating the operative signal input and adjusting the unit to obtain the specified output.

To calibrate a unit, proceed as follows:

NOTE

CALIBRATION DEPENDS ON ACCURATE TEST INSTRUMENTS AND STRICT TEST PROCEDURES.

- A. Connect the unit to the millivolt source using the positive (+) IN and negative (-) IN signal input terminals.
- B. Connect 12-42 Vdc in series with a digital multimeter ($\pm 0.05\%$ accuracy) to the positive (+) PS and negative (-) PS terminals on the MVX.
- C. Adjust millivolt source for zero output. Apply power to the MVX.
- D. Adjust millivolt source for output equal to lowest operation voltage.

- E. Use the DMM to monitor output and adjust ZERO for 0% output (4 mA or 10 mA).
- F. Adjust the millivolt source for output equal to highest operating voltage.
- G. Use the DMM to monitor output and adjust SPAN for 100% output (20 mA or 50 mA).
- H. Repeat Steps D through G until no further adjustment of the ZERO and SPAN pots is needed.
- I. Calculate 25%, 50%, and 75%, and adjust the millivolt source accordingly.
- J. Use the DMM and the input values calculated, check that output is linear (within $\pm 0.1\%$ of the output span).

2.6 CHANGING INPUT RANGE

The input range of the MVX may be changed in the field. Follow the disassemble procedures in Section 5. Change the circuit according to the specifications in Table 2-2.

NOTE

REFER TO THE SCHEMATIC AND ASSEMBLY DRAWINGS IN SECTION 6.

CAUTION

OBSERVE PROPER ASSEMBLY AND SOLDERING TECHNIQUES. SEE PARAGRAPH 5.4.3.

2.7 CHANGING OUTPUT SPAN

The output span of the MVX can also be changed in the field. To change the span, resistors need to be substituted. See table 2-3. Follow disassembly and re-assembly procedures in section 5.

CAUTION

Observe proper assembly and soldering techniques. (See paragraph 5.4.3.)

NOTE

Tables 2-2 and 2-3 DO NOT apply for units being configured for Elevated Zero (EZ).

NOTE

Refer to the schematic and assembly drawings in section 6.

**TABLE 2-2
INPUT RANGE**

Input (mV)	R305	R306	R307	R308	R310
5-10	12.4	100	90.9	17.4K	143K
10-20	10.5	200	169	35.7K	147K
20-40	15.0	412	332	73.2K	150K
40-80	221	806	1K	158K	137K
80-160	165	1.65K	2K	374K	140K
160-320	169	3.4K	6.19K	1.18M	133K

**TABLE 2-3
OUTPUT RANGE**

Input (mV)	Output (mV)	R4	R5	R6
5-10	4-20	84.5	52.3	32.4
5-10	10-50	32.4	19.1	13.0
10-20	4-20	84.5	53.6	31.6
10-20	10-50	32.4	18.7	13.0
20-40	4-20	84.5	53.6	32.4
20-40	10-50	32.4	19.1	13.0
40-80	4-20	84.5	53.6	32.4
40-80	10-50	32.4	19.1	13.0
80-160	4-20	84.5	53.6	32.4
80-160	10-50	32.4	19.1	13.0
160-320	4-20	84.5	53.6	32.4
160-320	10-50	32.4	19.1	13.3

3.1 GENERAL

Installation consists of checkout, calibration (if necessary), mechanical installation, and electrical connections. Checkout and calibration are detailed in Section 2, Calibration Procedures.

3.2 MECHANICAL INSTALLATION

The Model MVX is available in various physical configurations. Figure 3-1 illustrates the outline, dimensions, and other installation requirements for the "hockey puck" and RFI protected units.

Figure 3-2 illustrates the outline, dimensions and other installation requirements for the explosion proof conduit®. Be sure to observe all special procedures or precautions given with each illustration.

Although units are designed to operate in free air at a high ambient temperature, mount the unit on a surface that will serve as a heat sink if at all possible.

3.3 ELECTRICAL CONNECTIONS

Connections to the MVX are made to the terminal block on the front of the unit.

NOTE

THE MVX HAS NO CASE GROUND CONNECTION. IF POSSIBLE, DO NOT MOUNT THE UNIT IN ANY ELECTRICAL FIELD. SECURE THE ALUMINUM HP CASE TO A GOOD CONDUCTOR AT ZERO POTENTIAL.

3.3.1 WIRING PRACTICE

No special wire or cable is required for power and signal output connections to the unit.

Use AWG #20 wire. Signal wires do not require spade lugs or any other special preparation other than stripping 1/8 inch insulation from the end.

To avoid transients and stray pickups, it is recommended that twisted conductors be used where they run close to other services such as power lines.

3.4 BASIC HOOKUP

The MVX requires a 12-42 Vdc power supply. The basic electrical connections are shown in Figure 3-3.

Connect the negative (-) terminal of the 12-42 Vdc power supply to the negative (-) PS terminal of the MVX. Connect the positive (+) terminal of the power supply in series with the monitoring or control instrumentation to the positive (+) PS terminal of the MVX.

NOTE

OBSERVE PROPER POLARITY WHEN CONNECTING THE MVX.

3.4.1 GROUND CONNECTIONS

Both input and output may be grounded.

MVX input and output are transformer isolated with no dc connection between them. This isolation provides 100 dB common mode rejection and allows input to "float" with respect to output.

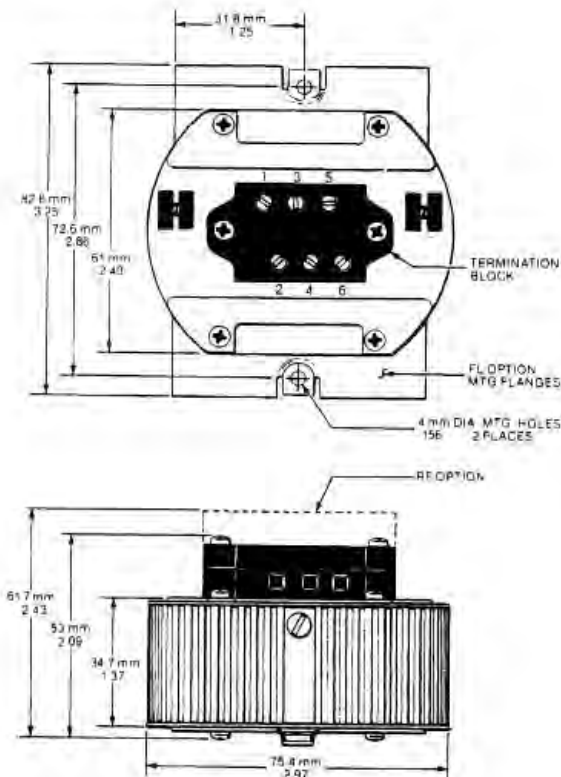
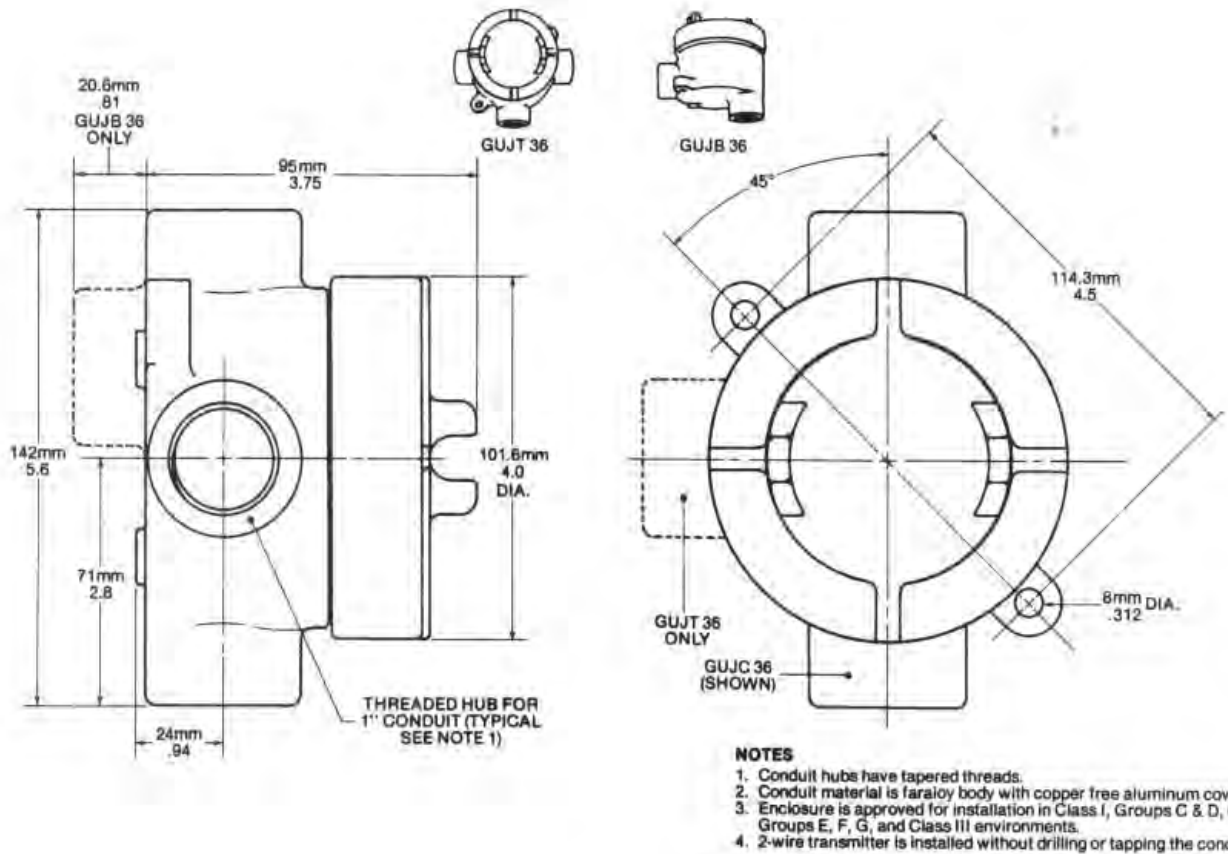

FIGURE 3-1
HP ENCLOSURE



**FIGURE 3-2
EXH2 ENCLOSURE**

3.5 TX OPTION

The MVX can be powered by using the TX option that supplies up to 24 mA @ 35 Vdc from several other Moore Industries modules. The TX option cannot, however, be used on 10-50 mA output. Figure 3-3 shows the connection to a typical Moore Industries module with TX option. Note the connection polarities.

3.6 PERIODIC VISUAL CHECK

Once calibrated and installed, the MVX operates

unattended. The only controls on the outside of the unit are the SPAN and ZERO potentiometers which require no further attention after initial adjustments. However, should a malfunction occur, refer to Section 5 for maintenance information.

A periodic check of input and output connection is recommended every six months to assure continued dependable operation.

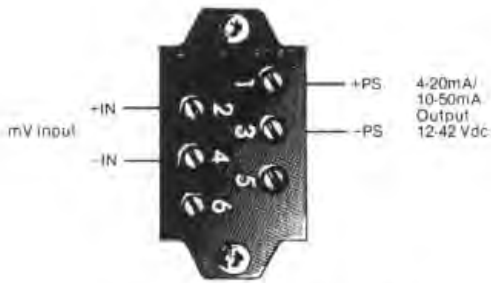

TERMINAL POSITIONS

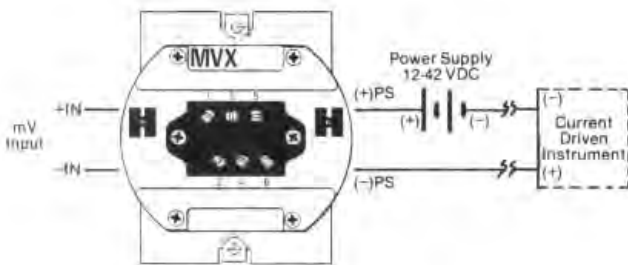

MVX CONNECTION USING SEPARATE POWER SUPPLY

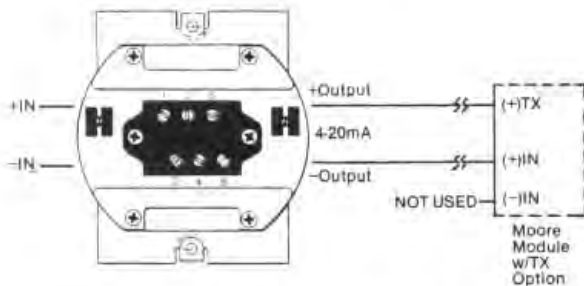

CONNECTION WITH TX OPTION

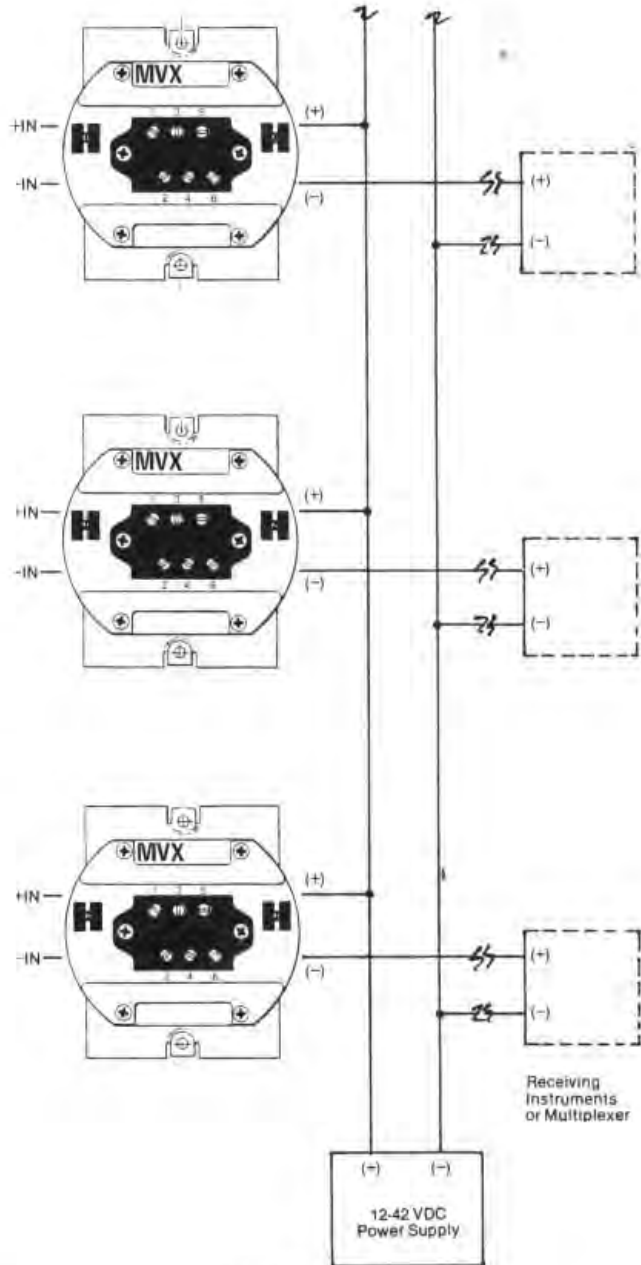

MVX CONNECTION WITH SINGLE INTERNAL POWER SUPPLY

FIGURE 3-3 CONNECTION DIAGRAMS

4.1 INTRODUCTION

This section describes the theory of operation of the Model MVX.

Become familiar with the input by reading "FUNDAMENTALS" (paragraph 4.2) and the *General* sections of the paragraphs that follow. The *Detailed* sections of the paragraphs below offer sufficient information to troubleshoot the unit.

The descriptions of how the circuit operates are based on the schematic diagram included in Section 6, Unit Documentation.

Reference designators for components are included in the detailed descriptions of circuit operations.

4.2 FUNDAMENTALS

The Model MVX produces variable current output proportional to millivolt input.

The MVX circuitry consists of: 1) a power supply; 2) a standardizing voltage-to-current input preamplifier — with zero adjustment and automatic compensation for open circuit condition; 3) a chopper to isolate input from output; 4) a demodulator; and 5) a current amplifier (a differential amplifier, plus an output power amplifier) with Adjustable span. (See Figure 4-1.)

4.3 POWER SUPPLY

General The power supply circuit consists of one

constant current source. The constant current source, a diode, drives a shunt regulator and an inverter (a stable multivibrator). With a transformer, the inverter generates a bipolar voltage supply for the output stages. The inverter transformer also isolates power for the input side of the MVX. Fed by the secondary of the inverter transformer, a bridge rectifier and filter circuit supply voltage to power the input preamplifier. A diode protects the MVX from polarity reversals due to human error or line transients.

Detailed Diode CR7 protects against polarity reversal, while constant current diode CR8 provides startup current of about 3 mA. Current from CR8 passes through resistors R17, R14, and R302 to provide about 7 volts through the shunt regulator which is made up of transistors Q301 and Q302 and resistor R303. The 7 volts from the shunt regulator powers an inverter which is made up of transistors Q304 and Q305. The inverter is basically an astable multivibrator with two extra driver transistors, Q303 and Q306. The collectors of Q303 and Q306 drive the primary winding of the inverter transformer, T1. The center tap of the primary winding, T1 PIN 5, goes to the positive end of the shunt regulator.

The inverter alternately pulls one end of the T1 primary high and the other end low. The transformer sees a full 14 volts across its centered-tapped primary winding, and autotransformer action begins. The 14 V square wave that is pro-

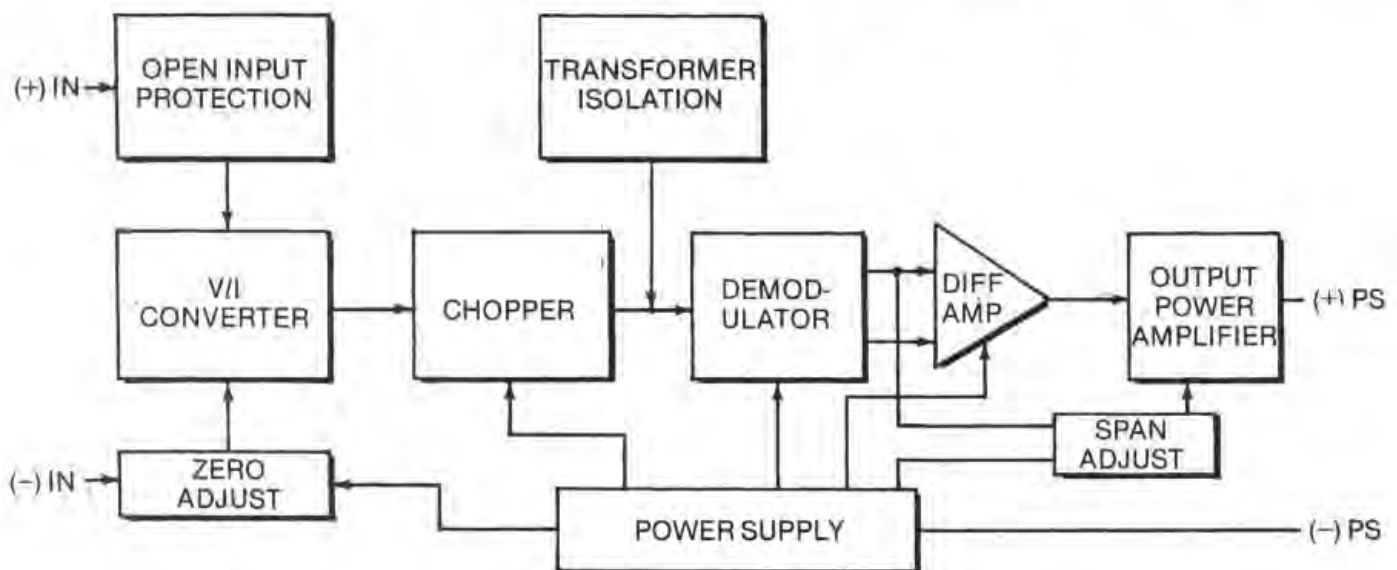

FIGURE 4-1
BLOCK DIAGRAM

duced is rectified by diodes CR301 and CR302 and then filtered by capacitor C301 to provide a 14 Vdc supply from A and F to power the differential amplifier, IC2.

The ends of the primary of inverter transformer T1 (PINS 4 and 6) also drive the two FETs (field effect transistors) in the demodulator.

The secondary of T1 feeds a bridge rectifier and filter stage made up of diodes CR1, CR2, CR3, and CR4 and capacitor C1. The rectifier provides power for the input side which is completely isolated from output power for the MVX. The isolated supply feeds a constant voltage source composed of zener diode CR9 and resistor R2 to create the reference voltage (6.4 ± 0.1 V) to power the input bias network and the reference junction compensation, RJC, network. Current through Q1 is about 500 microamps.

4.4 INPUT PREAMPLIFIER

General The input circuit is a standardizing voltage-to-current converter. Acting as a current source for the signal transformer, the preamp accepts a millivolt signal and provides a constant current proportional to input.

An input zero network and an input span network compensate for offset and sensitivity. Adjustment is provided with an externally accessible ZERO pot.

The input preamp also provides "open circuit protection." An open circuit drives the transmitter upscale to about a 150% reading. Optional burnout protection with downscale drive (DD option) is also available.

Detailed Accepting a wide variety of span and zero millivolts, the input preamplifier is a standardizing millivolt-to-microamp converter. Made up of IC1 and transistor Q4, the input preamp delivers a standardized signal to the primary winding of the signal transformer, T2. Output of the preamp is a current mode signal of typically 12.5 to 62.5 microamps. This span of 50 microamps also represents a 1:5 ratio — exactly the ratio required for an output span of 4-20 mA or the optional 10-50 mA output.

The input zero network consists of the ZERO potentiometer plus resistors R4, R1, and R5. These resistors run off the reference voltage, and they add or subtract the necessary millivolts. When input is proportional to 4 mA output, the zero network provides 12.5 microamps (and about 0.1 V) through resistor R7. The voltage across R7 varies from 0.1 to 0.5 V as the input varies from 0-100%.

The input span network is made up of resistors R8 and R3 which provide the gain needed to obtain the standardized current signal through R7. Capacitor C11 limits the speed of response of the

input circuit and provides normal mode rejection.

Upscale burnout protection is provided by connecting the input preamp to the positive power supply through resistor R19. If the signal drops to zero (because of burnout or an open circuit), the positive voltage through R19 drives the MVX to full output (150%) to alert control room operators that an alarm condition exists.

Optional downscale drive burnout protection is provided by connecting resistor R19 to C, the negative terminal of the power supply.

4.5 CHOPPER

General The standardized constant current from the input preamp is chopped at the primary side of a signal transformer that isolates input from output.

Detailed The signal is chopped at the primary of signal transformer T2 using diodes CR5 and CR6 and one end of Q4. CR5 and CR6 act as steering diodes and are connected to the secondary of T1, the inverter transformer. Because the duty cycle on the inverter — and hence on the ac on T1 — is about 50%, current goes through one-half of T2's primary and out the center tap half the time. The other half of the time, current goes in the other end of the primary and out the center tap. This results in a reversal of current through the primary of T2 which is used in a current mode.

(Shields in T1 and T2 divert to output common any capacity coupled common mode signals between input and output windings. This improves the common mode rejection ratio of the MVX.)

4.6 DEMODULATOR

General At the signal transformer secondary, the ac signal is converted back to dc with two field effect transistors operating in opposite phase to act as a demodulator.

Detailed The output side of the MVX has two demodulator switches, Q2 and Q3 (both FET transistors) that operate as a single-throw double-pole switch. The center of the switch goes to the inverting input of operational amplifier IC2. The op-amp runs with closed loop feedback to PIN 2 which looks like a virtual ground.

T2, the signal transformer, runs in a current mode, alternately steering current into one half of the primary and then the other. Synchronously, current is taken out of one half and then the other half of the secondary. Whenever current passes through CR5 (that is, when D is low and E is high), current also flows in Q2. When CR6 is conducting (E low, D high), Q3 conducts.

The demodulated dc signal is now ready for output amplification.

4.7 OUTPUT

General The output circuit of the MVX acts as a standardized current-amplifier. The standardized dc signal from the demodulator is boosted to standard process current level by an output power amplifier. This output amplifier is controlled by an op-amp. Output span is adjustable, and a maximum current limiter is provided.

Detailed Together, IC2, the output span network, and the output amplifier function as a standardizing microamp-to-milliamp converter.

The output span network consists of the SPAN pot and resistors R14 and R302, both used for current sensing. R14 is shunted by the SPAN pot. The demodulated current coming from Q2 and Q3

causes a voltage drop across R18 (one end of which is a virtual ground). This voltage is tapped by the SPAN pot wiper, and current must pass through the SPAN pot, R14 and R302 towards ground. IC2 supplies the voltage necessary to maintain this current.

Capacitor C9 which is connected between output and inverting input of IC2 (PIN 6 and PIN 2) provides 1½-2 Hz -3 dB rolloff on normal mode. (At 50-60 Hz, the unit has rolled off considerably and does not respond to these rapidly changing signals.)

The output amplifier is made up of transistors Q5 and Q6 and resistors R15 and R16. For a standardized input signal, output is 4-20 mA (or optional 10-50 mA).

5.1 GENERAL

This section offers information to help maintain the Model MVX. Disassembly instructions for all mechanical options are included, and a general guide to troubleshooting is provided. Precautions and special techniques for repair or component replacement are also described.

5.2 RESPONSIBILITY

The following paragraphs provide a guide for proper corrective maintenance of the unit. Such maintenance should be performed only by qualified technicians who have read and thoroughly understand Section 4, Theory of Operation.

CAUTION
IMPROPER REPAIR BY UNQUALIFIED PERSONNEL VOIDS THE MOORE INDUSTRIES WARRANTY.

5.3 DISASSEMBLY

Before troubleshooting, the unit must first be disassembled. The physical configuration of the unit determines which steps to follow in disassembly. (See Figure 5-1.)

NOTE
ALWAYS IDENTIFY SIGNAL WIRES — PREFERABLY BY TAGGING — BEFORE DISCONNECTING THEM.

CAUTION
DISCONNECT SOURCE POWER SUPPLY BEFORE DISASSEMBLING THE UNIT.

- A. Tag and disconnect the signal wires at the negative (-)PS and positive (+)PS terminals, and at the negative (-)IN and positive (+)IN signal input terminals.
- B. Loosen and remove the two Phillips-head screws that retain the terminal block. Unplug the terminal block from the PC board inside the enclosure.
- C. Loosen and remove the four Phillips-head screws that secure the top cover plate; remove the top cover plate.
- D. Loosen and remove the small Phillips-head set screw at the top of the case; it retains the PC assembly.

- E. Loosen and remove the screw at the bottom of the unit that heat sinks the output transistor Q5 to the case. Lift and remove the PC assembly.

NOTE

SAVE THE MICA WASHER THAT FITS BETWEEN Q5 AND THE CASE. MICA WASHER *MUST* BE REPLACED *FLAT SIDE UP* FOR PROPER REASSEMBLY.

- F. Remove the four screws that hold PC1 and PC3 together. A hinge of flexible ribbon conductor connects the two boards. Carefully separate the two boards to expose all components.
- G. Plug the terminal block back into the PC board. Plugging the terminal block back into the PC board simplifies power reconnection during test, and it protects the gold-plated contacts on the PC board connector.
- H. To reassemble the unit, reverse Steps A-G. See paragraphs 5.4.2 and 5.4.3 for tips and techniques on replacing components.

CAUTION

MAKING CONNECTIONS TO PC CONNECTORS WITH ALLIGATOR CLIPS OR SIMILAR MEANS IS CONSIDERED A PHYSICAL ABUSE OF THE UNIT. SUCH PRACTICE MAY DAMAGE THE CONTACTS AND VOID THE WARRANTY.

5.3.1 Explosion Proof (EX) Option

- A. Using a bar wrench, loosen and remove the cover from the explosion proof conduit.[®]
- B. Tag and disconnect the signal wires at the negative (-)PS and positive (+)PS terminals and at the negative (-)IN and positive (+)IN signal input terminals.
- C. A spring clip secures the MVX inside the conduit.[®] Squeeze the sides of the clip inward, and lift the entire unit out of the conduit.[®]
- D. Follow Steps A-G in Paragraph 5.3 for access to the PC assembly and components.

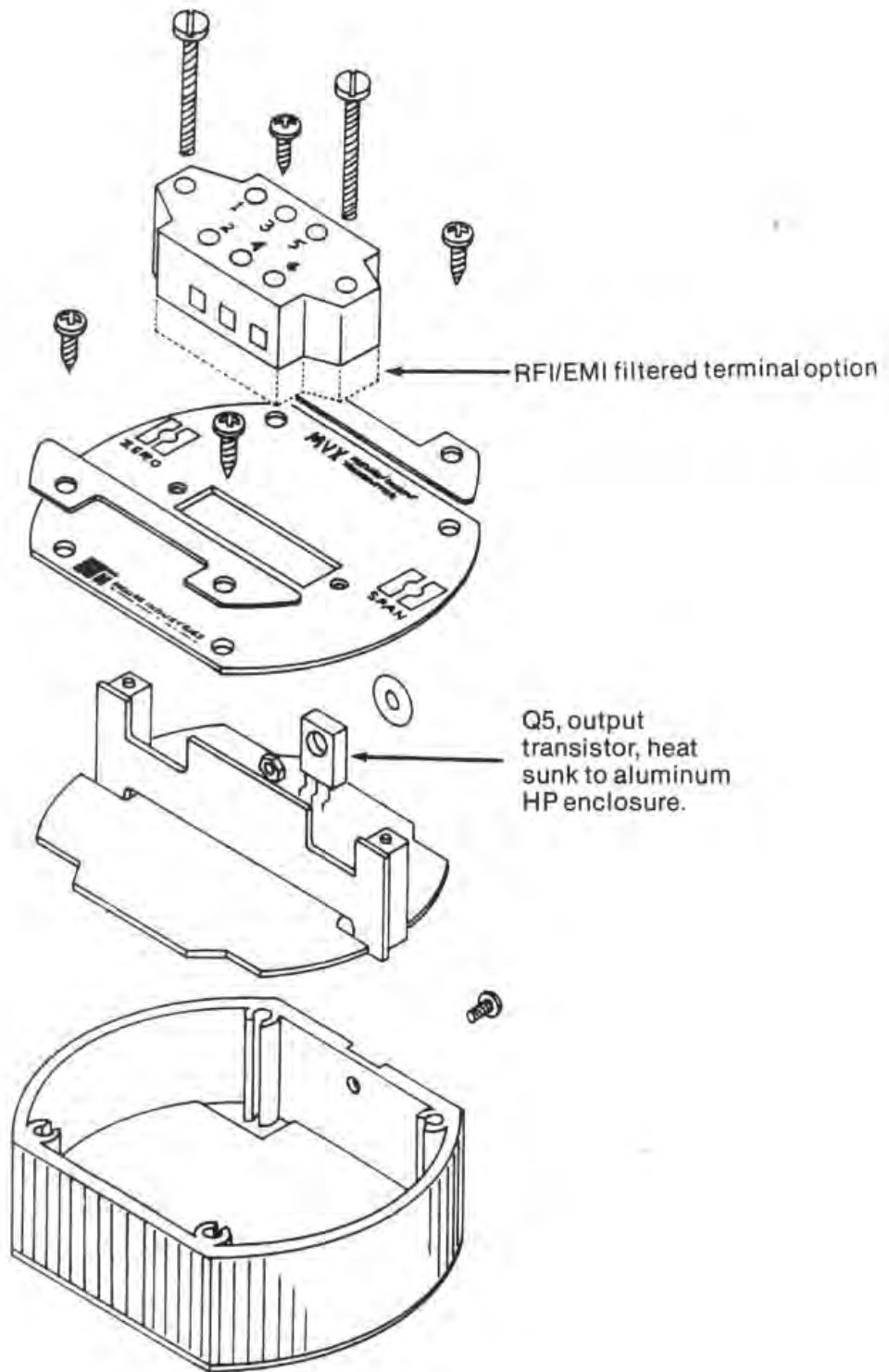

**FIGURE 5-1
EXPLODED VIEW OF HP**

5.3.2 RF Immune (RF) Option

On units with protection from radio frequency interference (RFI), a special filtered terminal assembly replaces the standard terminal block. Actual output connections to the MVX are made through a flexible ribbon cable wired between the printed circuit board and the patented filter assembly.

NOTE

BOTH THE RF TERMINAL BLOCK AND THE PC ASSEMBLY MUST BE REMOVED TOGETHER FOR MAINTENANCE.

- A. Tag and disconnect the signal wires at the negative (-) PS and positive (+) PS terminals and the negative (-) IN and positive (+) IN signal input terminals.
- B. Loosen and remove the four Phillips-head screws that secure the top cover plate. Do not remove the screws that secure the terminal block.
- C. Loosen and remove the small Phillips-head set screw on the top of the case; it retains the PC assembly.
- D. Loosen and remove the screw at the bottom of the unit that heat sinks the output transistor Q5 to the case. Lift and remove the PC assembly.

NOTE

SAVE THE MICA WASHER THAT FITS BETWEEN Q5 AND THE CASE. MICA WASHER MUST BE REPLACED FLAT SIDE UP FOR PROPER ASSEMBLY.

- E. Follow Steps F and G in Paragraph 5.3 for access to PC components.

CAUTION

THE FLEXIBLE RIBBON CABLE THAT INTERCONNECTS THE TERMINAL BLOCK AND THE PC BOARD IS SOLDERED AT ONE END TO THE TERMINAL BLOCK AND SOLDERED AT THE OTHER TO THE BC BOARD. HANDLE WITH CARE OR CONNECTIONS MAY BE DAMAGED.

CAUTION

THE PATENTED RF FILTER ASSEMBLY IS EXTREMELY DELICATE. HANDLE WITH CARE, AND AVOID EXCESS HEAT IF CONNECTIONS MUST BE UNSOLDERED OR RESOLDERED.

5.4 TROUBLESHOOTING

The schematic diagrams include flagged numbers (or letters) at various points in the circuit. Table 5-1 gives the voltages at these points for specific input conditions. The assembly drawing (See Section 6) shows the physical locations of the parts on the circuit board. Remember, the PC boards are protected with a moisture-resistant coating. Therefore, it may be necessary to use a needle-point probe and exert a fair amount of pressure to break through the coating to observe the voltage at a specific point. When connecting a probe to a component on the circuit board, be sure the probe does not short circuit to an adjacent component.

In general, troubleshooting is carried out by tracing the signal with a digital voltmeter (DVM) and referring to the schematic to determine which component is at fault. If a unit fails completely to operate, the most logical source of trouble is the power supply. If the unit produces incorrect (but not zero) output, check the output from the power supply. If these are normal, Test Point 2 (with respect to TP1) should vary from 0.1-0.5 V (approx) as the input varies from 0-100%. If this fails, IC1 or Q4 are likely suspects.

If Test Point 2 is normal, Test Point 3 should vary as follows: 0.28-1.4 V (if the unit was calibrated for minimum span); or 0.14-0.7 V (if the unit was calibrated for maximum span). If this fails, IC2 or transistors Q5 or Q6 could be the cause.

5.4.1 Cleaning PC Connectors

Occasionally, units that have been in service for a long time may develop resistive coatings on the gold-plated contacts on the PC board. Unless removed, this coating will cause the unit to malfunction.

Two types of coatings can develop on the contacts: inorganic and organic. Inorganic contamination results when copper "bleeds" through the gold-plating and oxidizes. Organic contamination results mainly from careless handling and usually consists of oils and salts deposited by fingerprints when the contacts are touched.

**TABLE 5-1
TEST VOLTAGES AND WAVEFORMS**

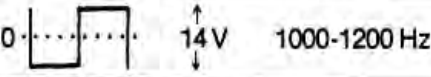
TEST POINT	WAVEFORM AND AMPLITUDE OR VOLTAGE LEVEL
A	+6.5 to 7 V (Referenced to Ground)
B C	12 V
D E	
F	-7 V (Referenced to Ground)
C 1	Reference Voltage, 6.4 ± 0.1 V
1 2	From 0.074-0.37 V to 0.148-0.74 V, depending on input
3	0.28-1.4 V @ min SPAN calibration 0.14-0.7 V @ max SPAN calibration

Removing Inorganic Contaminants:

- A. Immerse contacts in an ultrasonic bath of de-ionized water and a detergent, such as Liquinix, for at least 30 seconds.
- B. Repeat Step A with pure deionized water only.

CAUTION

IMMEDIATELY REMOVE WATER FROM CONTACTS. IF THIS IS NOT DONE QUICKLY, DAMAGE TO CONTACTS MAY RESULT.

- C. Remove water by immersing contacts in an ethane or methanol bath to same depth used in ultrasonic cleaning, Step A. NEVER WIPE OR USE AN ABRASIVE CLEANER ON THE CONTACTS. If wiping is necessary, use K-Dry towels or equivalent.

Removing Organic Contaminants:

- A. After inorganic contaminants and water have been removed, organic materials may be removed by immersing contacts in trichloroethane for at least 30 seconds.
- B. Let contacts air dry or wipe with a very fine, nonabrasive material such as K-Dry towels or equivalent.

CAUTION

NEVER USE AN ERASER ON CONTACTS. THE USE OF ABRASIVE CLEANERS OR ERASERS ON PLUG-IN BOARD CONTACTS IS CONSIDERED PHYSICAL ABUSE AND MAY VOID THE WARRANTY ON A PLUG-IN UNIT.

WARNING

TRICHLOROETHANE IS HIGHLY FLAMMABLE. DO NOT BREATHE THE FUMES.

5.4.2 Component Replacement

Replace all defective components with identical parts. Refer to Section 6 for a list of recommended replacement parts. The last row of numbers in the parts list is the number of spares to keep on hand for that part, per unit, for up to 10 units, a spares complement of 10% on the indicated parts should be used.

5.4.3 Tips & Techniques

Most of the parts used in the unit are quite small and located in a confined area. Professional electronic assembly hand tools are essential for servicing. The following paragraphs offer general repair techniques and precautions.

- A. Use a transformer-operated low-voltage soldering iron with a grounded tip and rated at not more than 50 watts. A temperature-controlled tip is desirable.
- B. Use extreme care when unsoldering the leads to any component. Do not keep the soldering iron on a point for more than a few seconds at a time. Use a suction-type solder removing tool (solder-sucker) as an aid in unsoldering transistors and integrated circuits. The moisture-proof protective coating on the PC board may be removed with trichloroethane.
- C. Do not excessively bend or twist the leads of components — they break easily.
- D. Before removing any component, carefully observe the lead dress. Be sure the lead dress of the replacement is identical with the original.
- E. Remove all flux from soldered joints with trichloroethane when repairs are completed.
- F. Test the repaired unit for proper operation by following the steps described in Section 2, Calibration Procedures. Adjust ZERO and SPAN as necessary to obtain the specified output.
- G. Reassemble the unit by reversing the procedure described in paragraph 5.3.

NOTE

Q5 IS HEAT SUNK TO ALUMINUM CASE. MICA WASHER AND SIDE OF TRANSISTOR THAT FITS AGAINST CASE MUST BE COATED WITH THERMO COMPOUND BEFORE INSTALLATION. DO NOT OVER-TIGHTEN OR TRANSISTOR WILL BREAK.

6.1 GENERAL

This section includes schematic(s), assembly drawings, and a computer printout parts list. The parts list includes the name of each item, a physical description, a reference designator keyed to the schematic and assembly drawings, a part number, and a recommended spares complement.

Wiring lists have also been included as necessary to aid maintenance personnel.

Parts information is grouped according to the number of assemblies in the unit. Because the MVX is built from three PC boards, the parts list is divided into three sections. The first item in each section identifies the assembly. A banner at the bottom of each page in the list identifies the unit.

6.2 LEGEND

ITEM: A reference for data processing and not used by maintenance personnel.

NAME: Gives the nomenclature of the part.

DESCRIPTION: Identifies the component by manufacturer's part number, usually followed by the component's parameters or value.

REF: Lists the reference designation for the components described in Section 4 and illustrated on the schematic and assembly drawings in Section 6.

PART NUMBER: Specifies the Moore Industries part number. THIS IDENTIFICATION MUST BE PROVIDED WHEN ORDERING PARTS FROM MOORE INDUSTRIES.

SPARE: Specifies the recommended number of component spares per unit type.

6.3 GLOSSARY OF ABBREVIATIONS

C.	Capacitor
CR	Diode (zener included)
HW	Special Hardware
J	Connecting buss wire
L	Inductor
LBL	Label
PC	Printed Circuit board
R	Resistor
T	Transformer
IC	Integrated Circuit
Q	Transistor
LED	Light Emitting Diode
TB	Terminal Block
VS	Voltage regulating varistor



MOORE INDUSTRIES
16550 Schoenborn Street
Sepulveda, California 91343

DO NOT SCALE DRAWING

TOLERANCES UNLESS NOTED	(DRAWN) <i>DL</i>	(CHECKED) <i>DL</i>	(ENGINEER) <i>DL</i>
X ±1			
XX ±.03			
XXX ±.010			
ANGLES ±30'			
SCALE NONE			

MVX
PC1, PC2, PC3

DRAWING NUMBER	108-405-00	REVISION	E
CATEGORY	SCHEMATIC		
REVISED BY	E.L. 5/14/62	DATE	5/14/62
BY	DL	APPROVAL	X

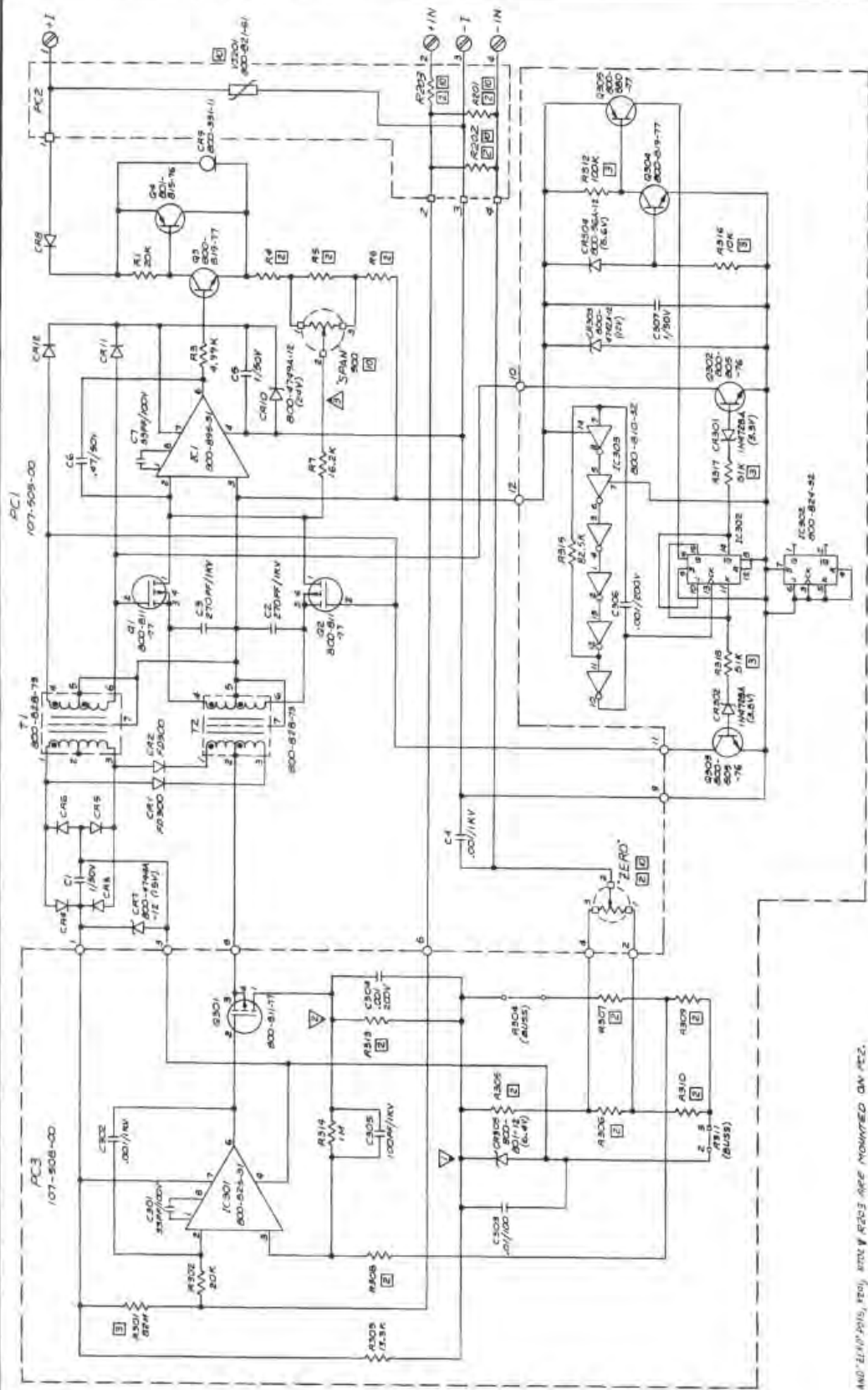

- 1. (1) 107-508-00, (2) 107-508-00, (3) 107-508-00, (4) 107-508-00, (5) 107-508-00, (6) 107-508-00, (7) 107-508-00, (8) 107-508-00, (9) 107-508-00, (10) 107-508-00, (11) 107-508-00.
- 2. RESISTANCE VALUES ARE IN OHMS; CAPACITANCE IN MICROGRAMS.
- 3. 0 FLEX JUMPER INTERCONNECT BETWEEN PC1 AND PC2.
- 4. 0 FLEX JUMPER INTERCONNECT BETWEEN PC2 AND PC3.
- 5. 0 FLEX JUMPER INTERCONNECT BETWEEN PC1 AND PC3.
- 6. 0 FLEX JUMPER INTERCONNECT BETWEEN PC1 AND PC2.
- 7. 0 FLEX JUMPER INTERCONNECT BETWEEN PC2 AND PC3.
- 8. 0 FLEX JUMPER INTERCONNECT BETWEEN PC1 AND PC3.
- 9. 0 FLEX JUMPER INTERCONNECT BETWEEN PC1 AND PC2.
- 10. 0 FLEX JUMPER INTERCONNECT BETWEEN PC2 AND PC3.
- 11. 0 FLEX JUMPER INTERCONNECT BETWEEN PC1 AND PC3.

NOTES: UNLESS OTHERWISE SPECIFIED:
1. ALL RESISTORS ARE METAL FILM (RVR5C) ± 1% TOL, 1/8 W, UNLESS OTHERWISE SPECIFIED.
2. ALL CAPACITORS ARE POLYESTER (PC) ± 5% TOL, UNLESS OTHERWISE SPECIFIED.
3. ALL DIODES ARE INFRARED (IR) UNLESS OTHERWISE SPECIFIED.
4. ALL TRANSISTORS ARE SILICON (SI) UNLESS OTHERWISE SPECIFIED.
5. ALL INTEGRATED CIRCUITS ARE METAL CAN (MC) UNLESS OTHERWISE SPECIFIED.
6. ALL POTENTIOMETERS INCREASE CLOCKWISE FROM PIN 1 TO PIN 2.
7. ALL CARBON COMP. RESISTORS (RCD) ± 0.5% TOL, 1/8 W.
8. SEE LIST OF MATERIALS FOR VALUE, PART NUMBER AND USAGE.
9. ALL DIMENSIONS ARE METAL FILM (RVR5C) ± 1% TOL, 1/8 W, UNLESS OTHERWISE SPECIFIED.

DO NOT SCALE DRAWING

TOLERANCES UNLESS NOTED	DRAWN	JAD	5/87
X = ± .1	CHECKED		
XX = ± .03	ENGINEER		
XXX = ± .010			
ANGLES: ± .30°			
HOLES: PER SAE STANDARD			
DIMENSIONS IN INCHES	SCALE	1 X 1	

CATEGORY
PC ASSEMBLY

TITLE

MXV-HP, PC2

DRAWING NUMBER

108-506-00

REVISED BY

ECO 6384

DATE

5/87

BY

[Signature]

APPROVAL

F

NOTICE RE PROPRIETARY INFORMATION: This drawing and the information contained herein are the proprietary property of Moore Industries - International, Inc. (MI) and should not be reproduced or disclosed to any third party without the written consent of an authorized officer of MI.

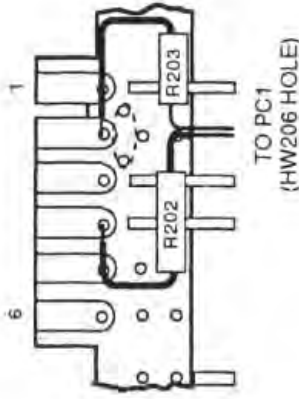
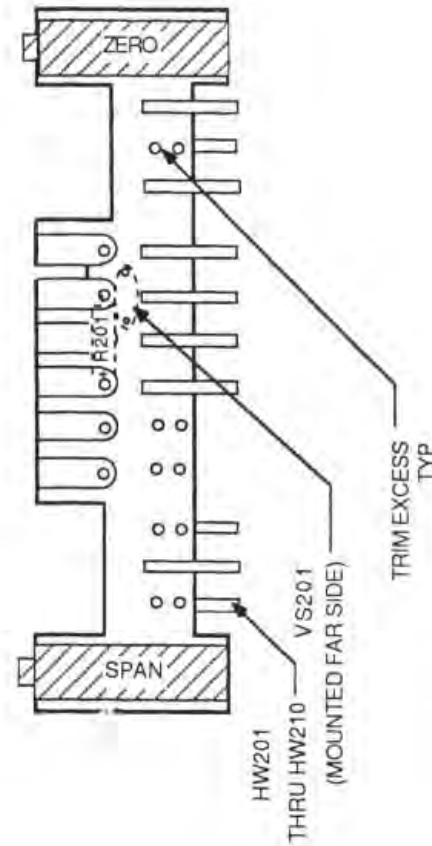

DETAIL A
R202 & R203

- 4. R201 & VS201 MOUNTED FAR SIDE.
- 3 HW206 NOT USED WHEN R202 & R203 ARE ADDED.
- 2. SLEEVE LEADS OF R202 & R203 WITH TEFLON SLEEVING.
- 1. ALL LEADS BE SOLDERED TO PADS.

NOTES:



MOORE INDUSTRIES

UNITED STATES

DO NOT SCALE DRAWING

TOLERANCES UNLESS NOTED	DRAWN	JAD	5/87
X = ± .1	CHECKED		
XX = ± .03	ENGINEER		
XXX = ± .010			
ANGLES: ± 30'			
HOLES: PER SAE STANDARD			
DIMENSIONS IN INCHES	SCALE	1 X 1	

CATEGORY PC ASSEMBLY
TITLE MVX-HP, PC2 -RF OPTION

DRAWING NUMBER 108-507-00

REVISED BY ECO 6384

DATE

BY

REVISION F

APPROVAL

NOTICE RE PROPRIETARY INFORMATION: This drawing and the information contained herein are the proprietary property of Moore Industries - International, Inc. (MII) and should not be reproduced or disclosed to any third party without the written consent of an authorized officer of MII.

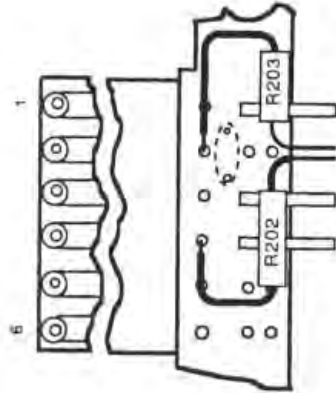
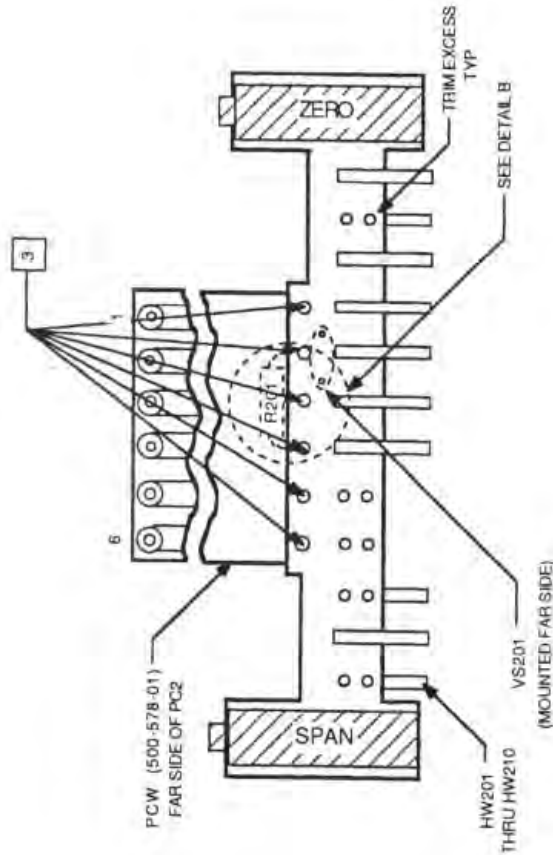

TO PC1 (HW206 HOLE)
1 2

DETAIL A
R202 & R203

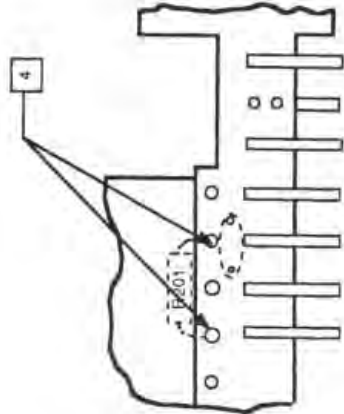

DETAIL B
R201

- 4. WHEN R201 IS USED, ITS LEADS REPLACE BUS WIRE SPECIFIED IN NOTE 3. MOUNT FAR SIDE.
- 3. INST./LL 22 AWG BUS WIRE THRU PC2 & PCW; SOLDER NEAR SIDE OF PC2 & FAR SIDE OF PCW.
- 2. HW20'S NOT USED WHEN R202 & R203 ARE ADDED.
- 1. SLEEVE LEADS OF R202 & R203 WITH TEFLON SLEEVING.

NOTES



MOORE INDUSTRIES
16650 Schoenborn Street
Sepulveda, California 91343

DO NOT SCALE DRAWING

TOLERANCES
UNLESS NOTED
.X ±.1
.XX ±.03
.XXX ±.010
ANGLES ±30'

DRAWN *[Signature]* 14 OCT 81
CHECKED
ENGINEER
SCALE 2/1

MVX
PCI

DRAWING NUMBER 108-505-00		REVISION 5
CATEGORY ASSEMBLY		
REVISED BY ECO 6384	DATE 10/20/81	BY JAO APPROVAL [Signature]

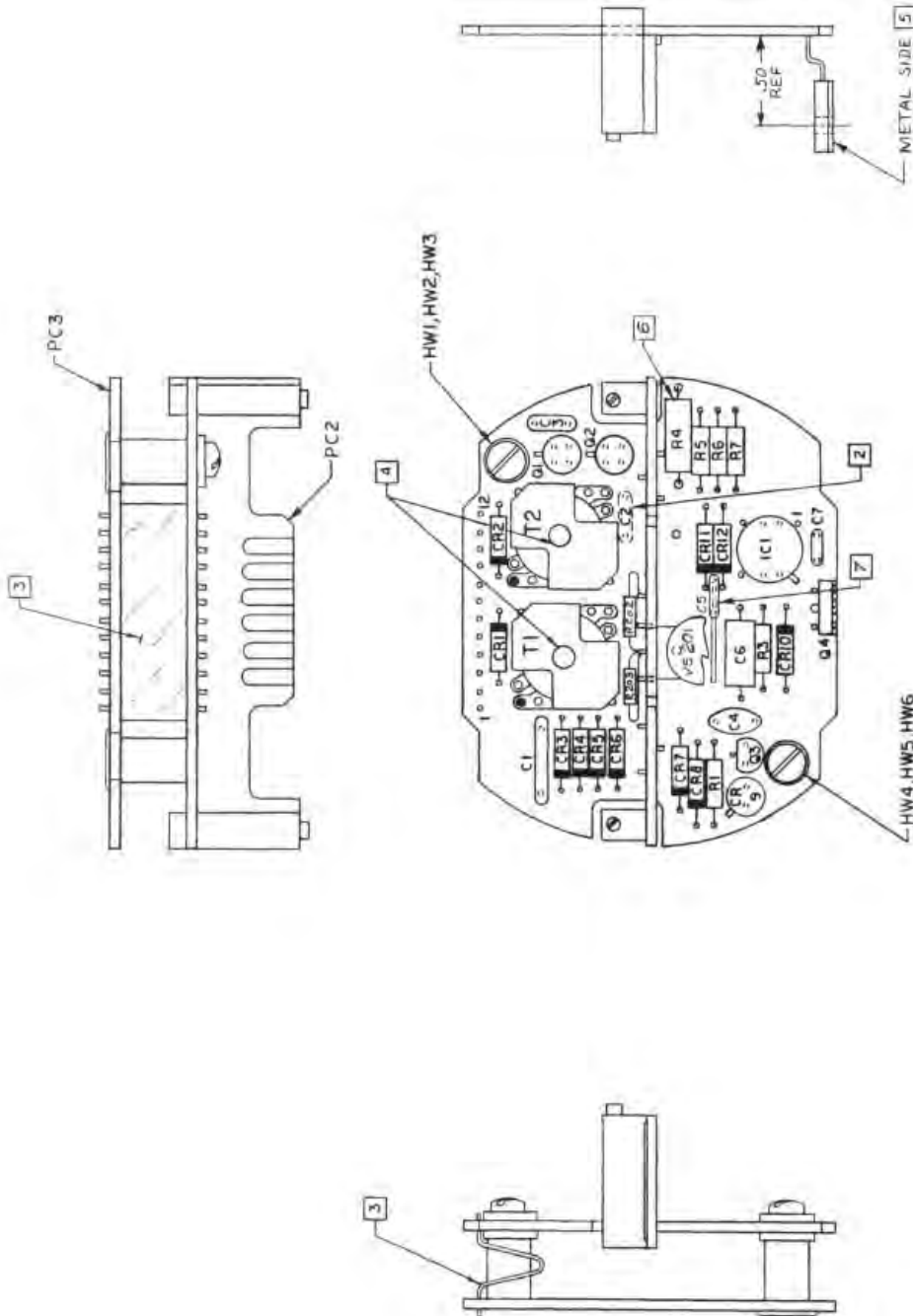

- 8 PC2 VS201, R202, R203 SHOWN FOR REFERENCE.
 7 OFFSET .25" WITH SLEEVED LEADS TO CLEAR V8 E01
 6 ELIMATE BODY OF R4, R16 (MIN) ABOVE PC1.
 5 BEND TRANSISTOR LEADS WITH TOOLING FIXTURE 200-213-11 BEFORE ASSEMBLY TO BOARD. USE TOOLING FIXTURE 200-213-10 TO HOLD TRANSISTOR IN PLACE WHEN SOLDERING, AS SHOWN IN SIDE VIEW.
 4 INSTALL HW7, HW8 BETWEEN PC1 AND T1, T2.
 3 FLEX JUMPER STRIP COMES WITH PC3, BEND INTO PLACE APPROX AS SHOWN.
 2 C2 TO BE MOUNTED ON FAR SIDE.
 1. ALL LEADS TO BE SOLDERED TO PADS.

NOTES:

DO NOT SCALE DRAWING	
TOLERANCES UNLESS NOTED	DRAWN BY <i>[Signature]</i> 7/2/67 BT
X ±.1	CHECKED
XX ±.03	DESIGNED BY
XXX ±.010	SCALE 2/1
ANGLES ±30'	

MVX
PC3

DRAWING NUMBER	108-508-00 D
CATEGORY	ASSEMBLY
REVISED BY	ECC 6303
DATE	7/2/67
BY	JGD
APPROVED	[Signature]

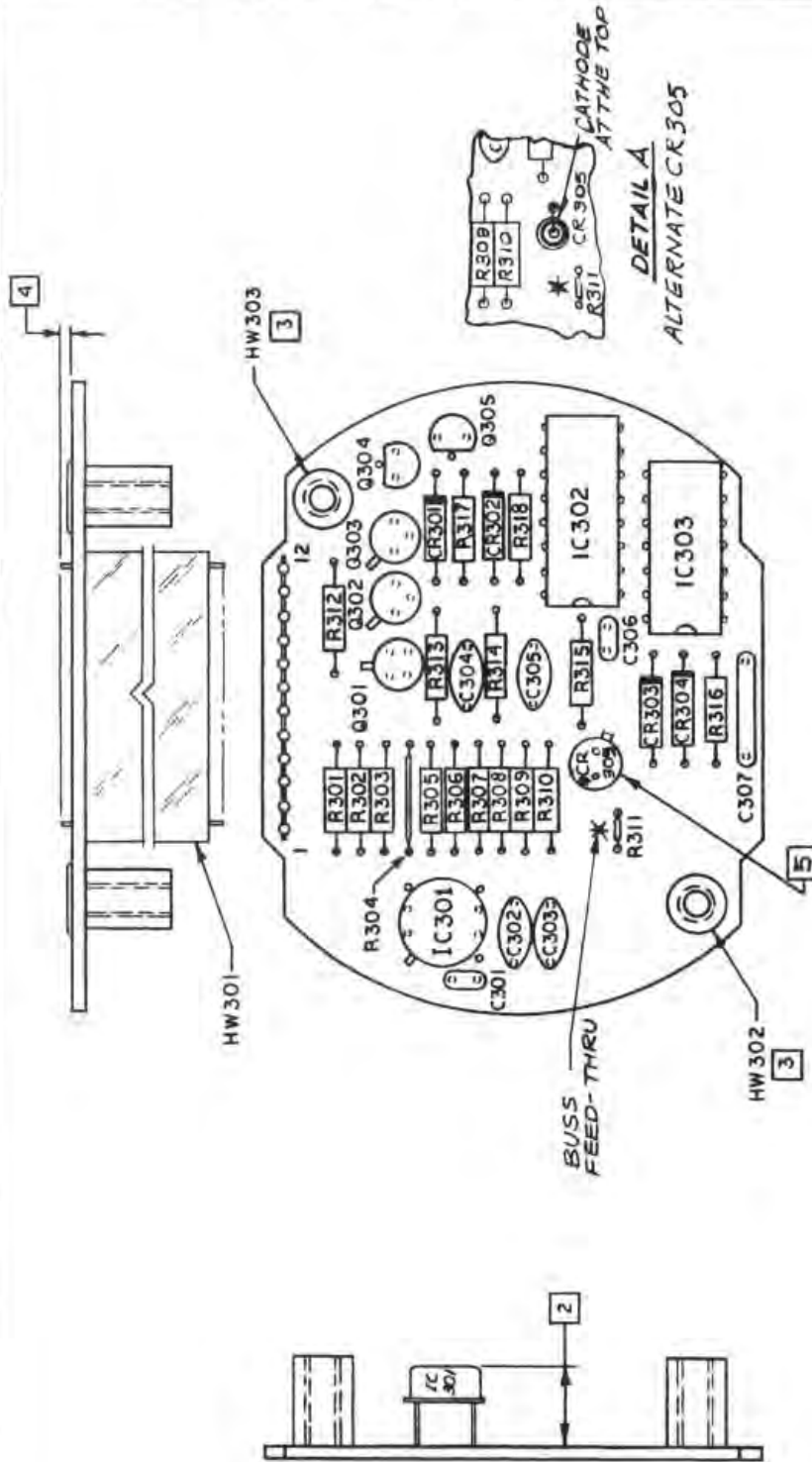

- 5 NOTE POLARITY DOT, OR SEE DETAIL A.
 - 4 NOT TO EXCEED .05 AFTER INSTALLATION.
 - 3 SWAGE FAR SIDE.
 - 2 MAX HEIGHT AFTER INSTALLATION NOT TO EXCEED .330.
- NOTES:
 1. ALL LEADS TO BE SOLDERED TO PADS.



MOORE INDUSTRIES
16650 Scheenborn Street
Sepulveda, California 91343

DO NOT SCALE DRAWING

TOLERANCES
UNLESS NOTED
X .03
XX .015
XXX .010
ANGLES ±30°

DRAWN R Kellow 7/73
CHECKED
APPROVED
SCALE

MVX DIN
PCI, PC2 + PC3

DRAWING NUMBER
108-409-00

REVISION
3

CATEGORY
SCHEMATIC

REVISED BY GKB
DATE 7/9/81
BY
APPROVAL

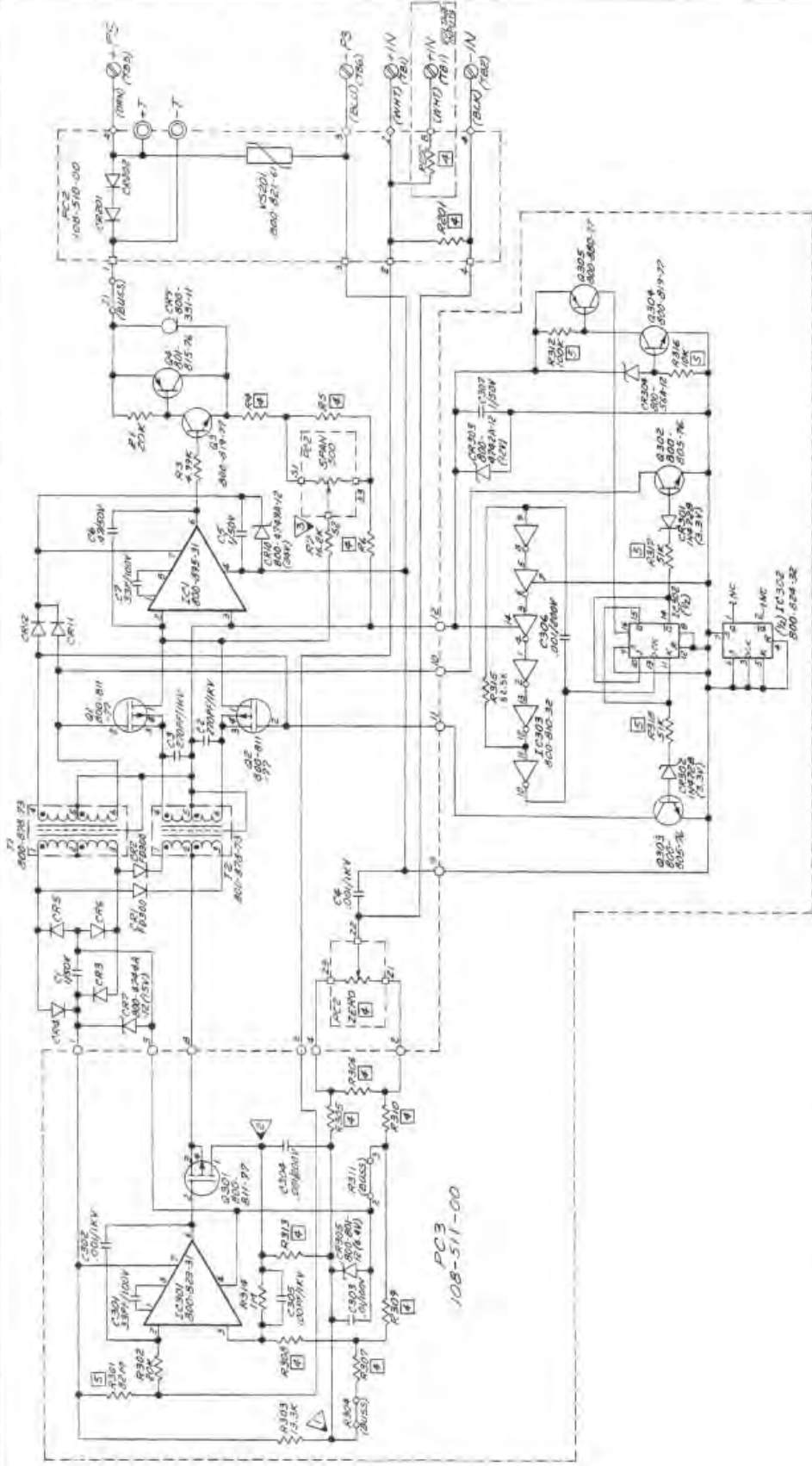

1. TEST JACK IN FRONT PANEL FOR 100-ohm TYP PROBE.
 2. 100-ohm FLEX DUMPER INTERCONNECT.
 3. 100-ohm INTERCONNECT PIN.
 4. WIRING PAD ON PC2.
 5. TEST POINT, FILLED END IS POINTED REFER TO SECTION 5 OF MANUAL, MAINTENANCE.
 6. SCREEN TERMINAL CONNECTION.
 7. POTENTIOMETERS INCREASE CLOCKWISE FROM 1 TO 3.
 8. CARBON COMP RESISTOR (PC207G) ±10%, 1/4W.
 9. SEE LIST OF MATERIALS FOR VALUES, PART NO. AND/OR USAGE.
 10. ALL DIMENSIONS ARE 100-414-11 (REV. 1/80).
 11. ALL RESISTORS ARE (UNLESS) METAL FILM, 1/4W.
 12. RESISTANCE IN OHMS; CAPACITANCE IN MICROFARADS.
- NOTES: UNLESS OTHERWISE SPECIFIED.

DO NOT SCALE DRAWING	
TOLERANCES UNLESS NOTED	DRAWN R Kelley 7/29/83
X ±.1	CHECKED
.XX ±.03	ENGINEER
.XXX ±.010	SCALE 2-1
ANGLES ±30'	

MVX DIN

PC1

DRAWING NUMBER 108-509-00	REVISION E
CATEGORY ASSEMBLY	
REVISED BY ECO # 6384	DATE 7-29-83
BY	APPROVAL

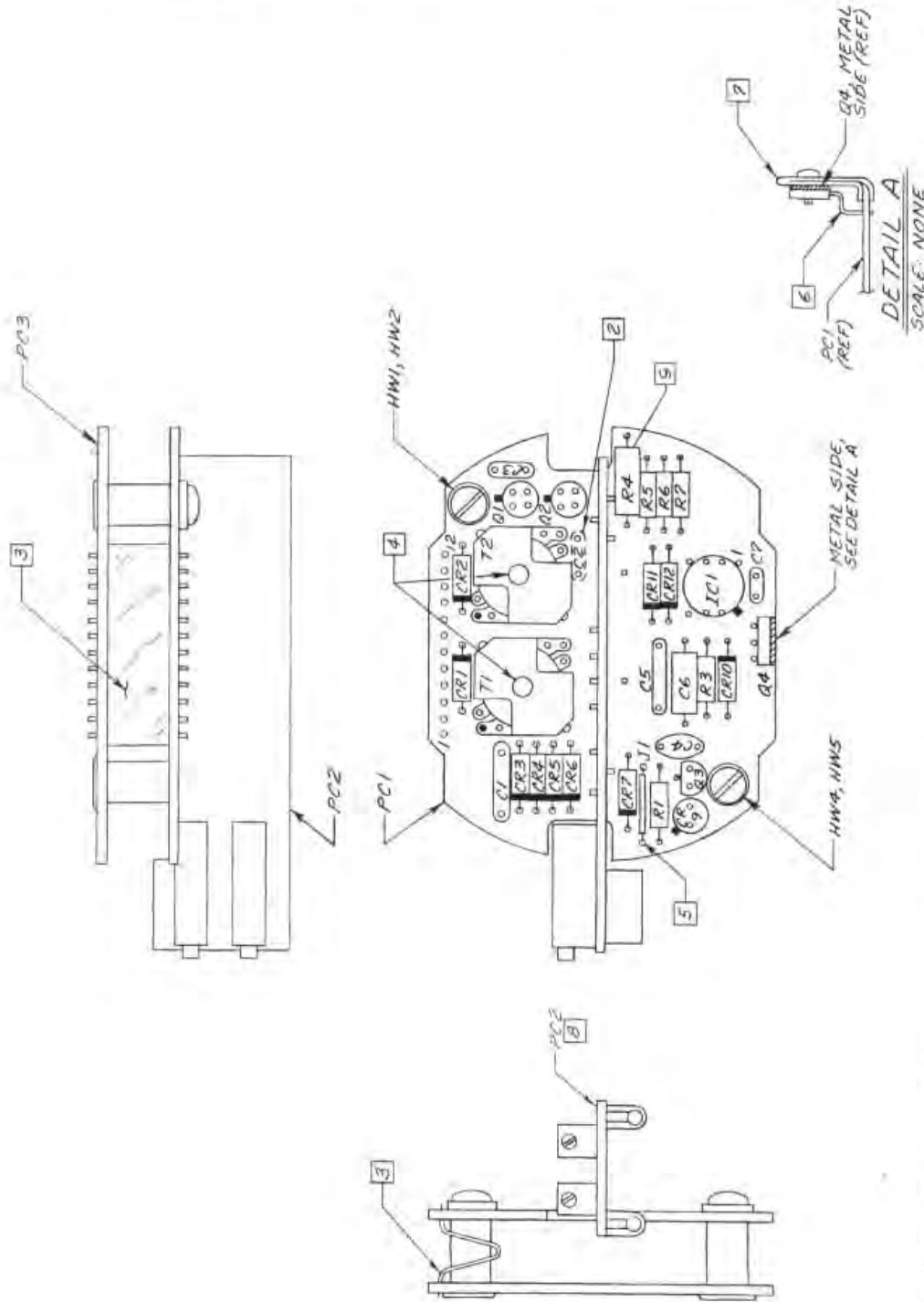

3. ELEVATE BODY OF X-4 1/16" (MIN) ABOVE PC1.
 4. PC2 MUST SIT FLAT ON & PERPENDICULAR TO PC1.
 5. USE FIXTURE 200-213-10 TO HOLD Q4 IN PLACE WHEN SOLDERING.
 6. USE FIXTURE 200-213-11 FOR BENDING Q4 LEADS.
 7. JUMPER IS DRAWN BUS, TEFLON SLEEVED.
 8. INSTALL HW7 & HW8 BETWEEN PC1 & T1, T2.
 9. FLEX JUMPER STRIP COMES WITH PC3; BEND INTO PLACE APPROX. AS SHOWN.
 10. CE TO BE MOUNTED ON FAR SIDE OF PC1.
 11. ALL LEADS TO BE SOLDERED TO PADS.
- NOTES:**

DO NOT SCALE DRAWING

TOLERANCES
 UNLESS NOTED
 X ± .1
 XX ± .03
 XXX ± .010
 ANGLES ± 30°

DRAWN R. Kelley 7/29/83
 CHECKED
 ENGINEER
 DATE 2-1

MVX DIN
 PC2

DRAWING NUMBER 108-510-00
 CATEGORY ASSEMBLY
 REVISED BY ECO # 6338
 DATE 1/15/87
 APPROVAL

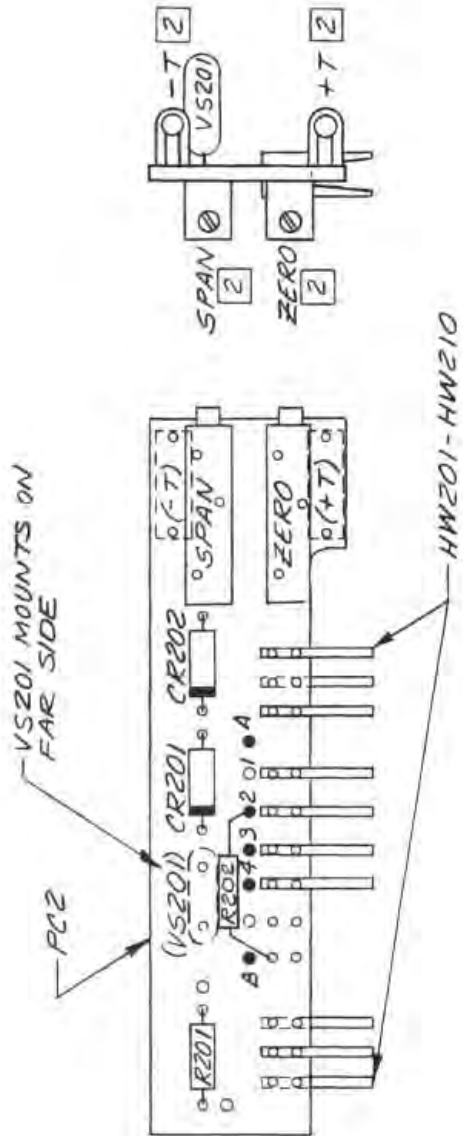

3. ALL WIRES TO BE INSERTED FROM FAR SIDE OF PC2.
 2. SPAN, ZERO, +T & -T MUST MOUNT FLAT ON BOARD.
 1. ALL LEADS TO BE SOLDERED TO PADS.
- NOTES:

DO NOT SCALE DRAWING	
TOLERANCES UNLESS NOTED	DRAWN <i>R. Kelley</i> 9/83
X ±.1	CHECKED
XX ±.03	ENGINEER
XXX ±.010	SCALE <i>2-1</i>

**MVX DIN
PC3**

DRAWING NUMBER 108-511-00	REV. 3 B
CATEGORY ASSEMBLY	REVISIONS
REVISED BY ELC * 6201	DATE 1/2/87
BY JD	APPROVED TR

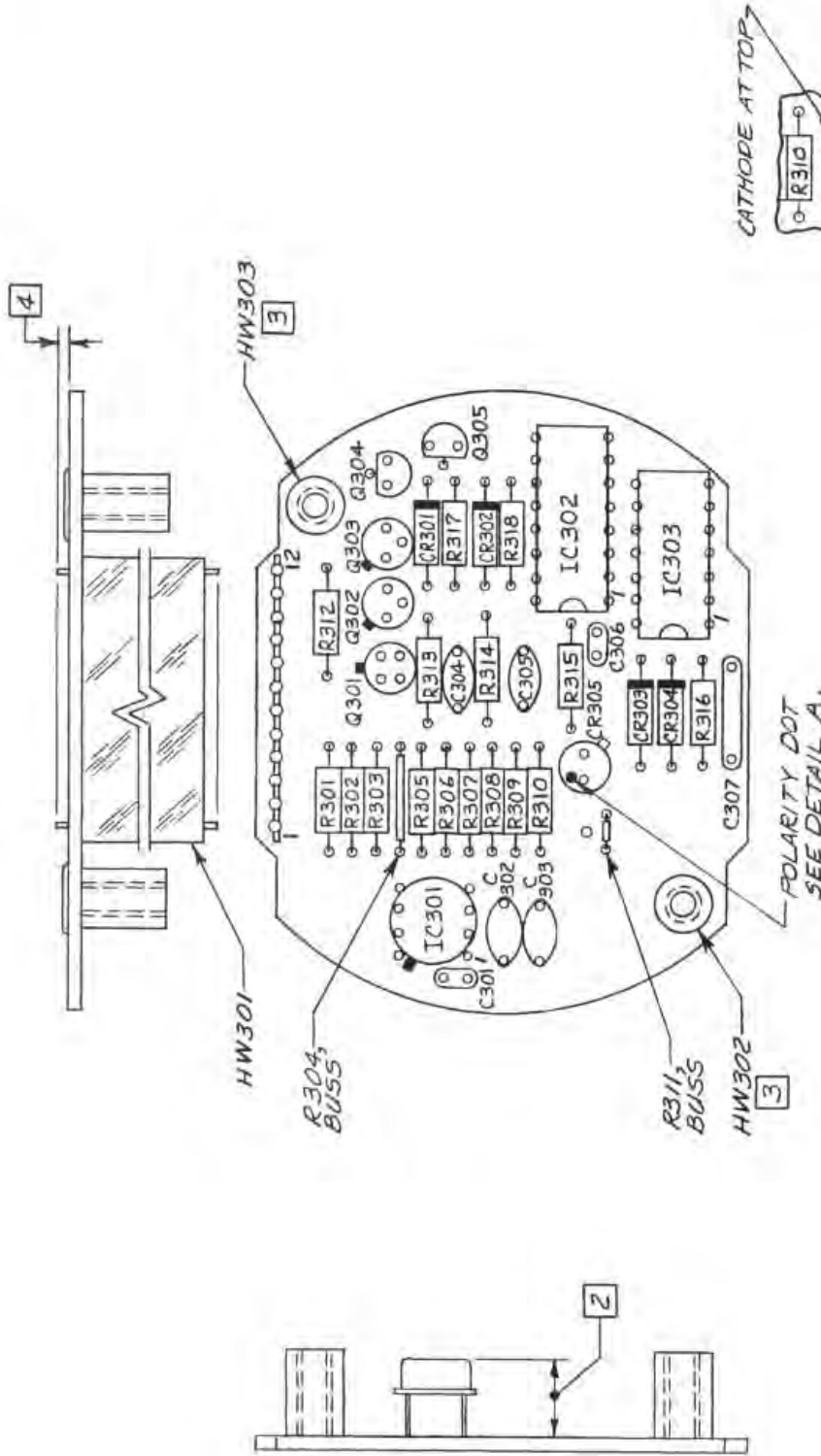

CATHODE AT TOP
 DETAIL A
 ALTERNATE CR305

- NOTES:**
1. .06 MAX, AFTER INSTALLATION.
 2. SWAGE IN BOARD FAR SIDE.
 3. MAX. HEIGHT TO BE .300
1. ALL LEADS TO BE SOLDERED TO PADS.



MOORE INDUSTRIES
16650 Schoenborn Street
Sepulveda, California 91343

DO NOT SCALE DRAWING

TOLERANCES
(UNLESS NOTED)
.X ±.1
XX ±.03
XXX ±.010
ANGLES ±30°

DESIGNED BY *R. Kelley* 3/29/83
CHECKED
ENGINEER
SCALE 2-1

MVX DIN
PC2

DRAWING NUMBER 108-510-00
CATEGORY ASSEMBLY
REVISED BY ECO # 6338
DATE 1/15/83
BY
APPROVAL

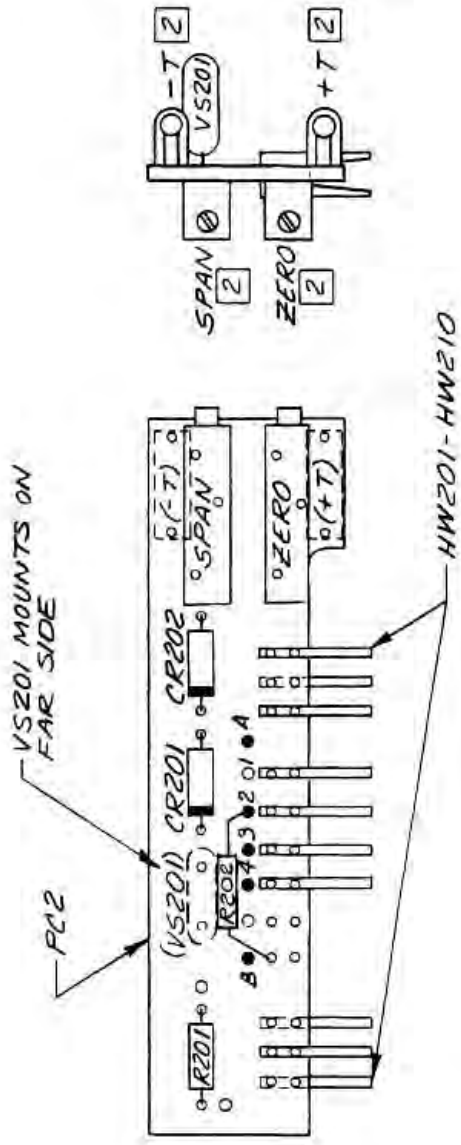

3. ALL WIRES TO BE INSERTED FROM FAR SIDE OF PC2.
2. SPAN, ZERO, +T & -T MUST MOUNT FLAT ON BOARD.
1. ALL LEADS TO BE SOLDERED TO PADS.

NOTES:

DO NOT SCALE DRAWING	
TOLERANCES UNLESS NOTED	DRAWN R. Kelley 9/83
X ±.1	CHECKED
XX ±.03	ENGINEER
XXX ±.010	SCALE 2-1
ANGLES ±30'	

**MVX DIN
PC3**

DRAWING NUMBER 108-511-00	REVISION B
CATEGORY ASSEMBLY	REVISED BY ELO*6201
DATE 1/2/87	BY JD
APPROVED [Signature]	

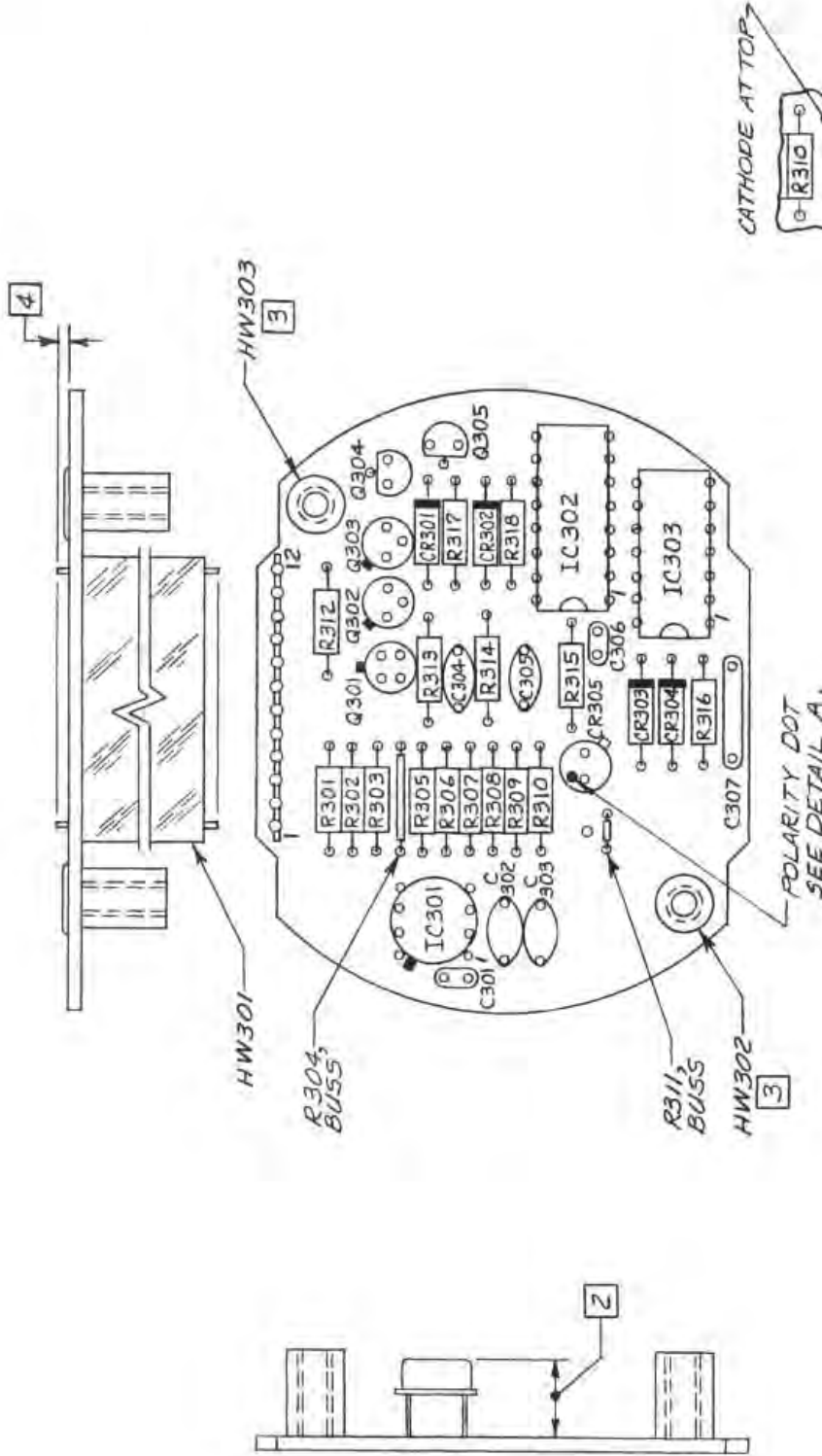

CATHODE AT TOP
DETAIL A
 ALTERNATE CR305

- NOTES:**
1. .06 MAX, AFTER INSTALLATION.
 2. SWAGE IN BOARD FAR SIDE.
 3. MAX. HEIGHT TO BE .300
 4. ALL LEADS TO BE SOLDERED TO PADS.

RETURN PROCEDURES

To return equipment to Moore Industries for repair, follow these four steps:

1. Call Moore Industries and request a Returned Material Authorization (RMA) number.

Warranty Repair –

If you are unsure if your unit is still under warranty, we can use the unit's serial number to verify the warranty status for you over the phone. Be sure to include the RMA number on all documentation.

Non-Warranty Repair –

If your unit is out of warranty, be prepared to give us a Purchase Order number when you call. In most cases, we will be able to quote you the repair costs at that time. The repair price you are quoted will be a "Not To Exceed" price, which means that the actual repair costs may be less than the quote. Be sure to include the RMA number on all documentation.

2. Provide us with the following documentation:
 - a) A note listing the symptoms that indicate the unit needs repair
 - b) Complete shipping information for return of the equipment after repair
 - c) The name and phone number of the person to contact if questions arise at the factory
3. Use sufficient packing material and carefully pack the equipment in a sturdy shipping container.
4. Ship the equipment to the Moore Industries location nearest you.

The returned equipment will be inspected and tested at the factory. A Moore Industries representative will contact the person designated on your documentation if more information is needed. The repaired equipment, or its replacement, will be returned to you in accordance with the shipping instructions furnished in your documentation.

WARRANTY DISCLAIMER

THE COMPANY MAKES NO EXPRESS, IMPLIED OR STATUTORY WARRANTIES (INCLUDING ANY WARRANTY OF MERCHANTABILITY OR OF FITNESS FOR A PARTICULAR PURPOSE) WITH RESPECT TO ANY GOODS OR SERVICES SOLD BY THE COMPANY. THE COMPANY DISCLAIMS ALL WARRANTIES ARISING FROM ANY COURSE OF DEALING OR TRADE USAGE, AND ANY BUYER OF GOODS OR SERVICES FROM THE COMPANY ACKNOWLEDGES THAT THERE ARE NO WARRANTIES IMPLIED BY CUSTOM OR USAGE IN THE TRADE OF THE BUYER AND OF THE COMPANY, AND THAT ANY PRIOR DEALINGS OF THE BUYER WITH THE COMPANY DO NOT IMPLY THAT THE COMPANY WARRANTS THE GOODS OR SERVICES IN ANY WAY.

ANY BUYER OF GOODS OR SERVICES FROM THE COMPANY AGREES WITH THE COMPANY THAT THE SOLE AND EXCLUSIVE REMEDIES FOR BREACH OF ANY WARRANTY CONCERNING THE GOODS OR SERVICES SHALL BE FOR THE COMPANY, AT ITS OPTION, TO REPAIR OR REPLACE THE GOODS OR SERVICES OR REFUND THE PURCHASE PRICE. THE COMPANY SHALL IN NO EVENT BE LIABLE FOR ANY CONSEQUENTIAL OR INCIDENTAL DAMAGES EVEN IF THE COMPANY FAILS IN ANY ATTEMPT TO REMEDY DEFECTS IN THE GOODS OR SERVICES. BUT IN SUCH CASE THE BUYER SHALL BE ENTITLED TO NO MORE THAN A REFUND OF ALL MONIES PAID TO THE COMPANY BY THE BUYER FOR PURCHASE OF THE GOODS OR SERVICES.

ANY CAUSE OF ACTION FOR BREACH OF ANY WARRANTY BY THE COMPANY SHALL BE BARRED UNLESS THE COMPANY RECEIVES FROM THE BUYER A WRITTEN NOTICE OF THE ALLEGED DEFECT OR BREACH WITHIN TEN DAYS FROM THE EARLIEST DATE ON WHICH THE BUYER COULD REASONABLY HAVE DISCOVERED THE ALLEGED DEFECT OR BREACH, AND NO ACTION FOR THE BREACH OF ANY WARRANTY SHALL BE COMMENCED BY THE BUYER ANY LATER THAN TWELVE MONTHS FROM THE EARLIEST DATE ON WHICH THE BUYER COULD REASONABLY HAVE DISCOVERED THE ALLEGED DEFECT OR BREACH.

RETURN POLICY

For a period of thirty-six (36) months from the date of shipment, and under normal conditions of use and service, Moore Industries ("The Company") will at its option replace, repair or refund the purchase price for any of its manufactured products found, upon return to the Company (transportation charges prepaid and otherwise in accordance with the return procedures established by The Company), to be defective in material or workmanship. This policy extends to the original Buyer only and not to Buyer's customers or the users of Buyer's products, unless Buyer is an engineering contractor in which case the policy shall extend to Buyer's immediate customer only. This policy shall not apply if the product has been subject to alteration, misuse, accident, neglect or improper application, installation, or operation. THE COMPANY SHALL IN NO EVENT BE LIABLE FOR ANY INCIDENTAL OR CONSEQUENTIAL DAMAGES.



WORLDWIDE • www.miinet.com

United States • info@miinet.com Tel: (818) 894-7111 • FAX: (818) 891-2816	Belgium • info@mooreind.be Tel: 03/448.10.18 • FAX: 03/440.17.97	China • sales@mooreind.sh.cn Tel: 86-21-62491499 • FAX: 86-21-62490635
Australia • sales@mooreind.com.au Tel: (02) 8536-7200 • FAX: (02) 9525-7296	The Netherlands • sales@mooreind.nl Tel: (0)344-617971 • FAX: (0)344-615920	United Kingdom • sales@mooreind.com Tel: 01293 514488 • FAX: 01293 536852